

ENGINEERING THEORY AND DESIGN CONSIDERATIONS

Contents

Introduction	C-2
Design Basis	C-2
Fluid Dynamics	C-4
Non-Compressible Fluids	C-4
Calculating System Pressure Drop	C-7
Compressible Fluids	C-10
Thermal Expansion Design	C-11
Thermal Expansion (single wall)	C-11
Thermal Expansion (double wall)	C-16
Duo-Pro and Fluid-Lok Systems	C-16
Poly-Flo Thermal Expansion Design	C-20
Hanging Practices	C-21
Burial Practices for Single Wall Piping	C-23
Burial Practices for Double Wall Piping	C-25
Installation of a Buried System	C-26
Pipe Bending	C-28
Heat Tracing and Insulation	C-29
Thermal Design	C-29
Ext. Self-Regulating Elec. Heat Tracing Design	C-30

INTRODUCTION

This section of the guide is to assist in the engineering and theory of a thermoplastic pipe system. Asahi/America provides the theory and the data on the design within this section. When designing a pipe system, all of the topics in this section should be considered. The complexity of your system will dictate how detailed the engineering needs to be. For safety reasons, it is important to consider all topics.

While thermoplastics provide many advantages in terms of weight, cleanliness, ease of joining, corrosion resistance, and long life, it does require different considerations than that of metal pipe and valves. Like any product on the market, thermoplastic has its advantages and its limitations. Use the engineering data in this section, coupled with the design requirements of Section D, for optimal results in a thermoplastic piping system.

DESIGN BASIS

Outside Diameter of Pipe

Outside diameter (OD) of piping is designed, produced, and supplied in varying standards worldwide. The two prevalent systems are metric sizes and iron pipe sizes (IPS).

IPS is a common standard in the United States for both metal and plastic piping. PVC, C-PVC, stainless steel, high density polyethylene (as examples) are generally found with an IPS OD. The difference is the inside diameter (ID). Each of these materials will be produced with a different ID based on the wall thickness.

Asahi/America pipe systems are provided both in metric and IPS OD dimensions depending on the material. Polypropylene and PVDF systems are always produced to metric outside diameters. However, these systems are also provided with standard ANSI flanges and NPT threads to accommodate attaching to standard US equipment and existing pipe systems.

Inside Diameter and Wall Thickness

The ID of a pipe can be based on various standards. The two common standards for determining the ID or wall thickness of a pipe is a Schedule rating and a Standard Dimensional Ratio (SDR).

Normally metal pipes and PVC pipes are sized according to Schedule ratings. A common Schedule rating for PVC is Sch 40 or 80. The higher the number, the higher the pressure rating. In schedule systems, no matter what the material, the wall thickness will always be the same. For example, a Sch 40 PVC pipe will have the same wall thickness as a Sch 40 PVDF pipe. However, due to the differences in material properties, these pipes will have very different pressure ratings. Schedule ratings offer the convenience of tradition and dimensional consistency.

Since all plastic materials have varying strength and are normally connected with 150 psi flanges, Schedule ratings are not really the best standard to be used. If a material offers superior mechanical strength, such as PVDF, it can be extruded with a thinner pipe wall than perhaps a Sch 80 rating, while still providing a 150 psi rating. The conclusion is that Schedule ratings ignore material properties, and in many cases, waste excess material and cost just to meet the required wall thickness of the standard.

A better system being used is SDR. This is a ratio between the OD of the pipe and the wall thickness. SDR is simply the outside diameter of the pipe divided by the wall thickness.

All PVDF and polypropylene pipes supplied by Asahi/America are produced according to ISO 4065 standards, which outlines a universal wall thickness table. From the standard, the following equation for determining wall thickness is derived.

$$\frac{2S}{P} = \frac{D}{t} - 1 = (\text{SDR}) - 1 \quad (\text{C-1})$$

which can be reconfigured to determine pipe and wall thickness as:

$$t = D \frac{1}{\left(\frac{2S}{P} + 1\right)} \quad (\text{C-2})$$

Where: D = outside diameter
 t = wall thickness
 P = allowed pressure rating
 S = design stress

The design stress is based on the hydrostatic design basis (HDB) of the material.

$$S = (\text{HDB}) / F \tag{C-3}$$

where F is a safety factor.

HDB is determined from testing the material according to ASTM D 2837-85 to develop a stress regression curve of the material over time. By testing and extrapolating out to a certain time, the actual hoop stress of the material can be determined. From the determination of the actual HDB, the exact allowed pressure rating and required wall thickness is determined. The advantage is that piping systems based on SDR are properly designed based on material properties instead of a random wall thickness.

One key advantage to using SDR sizing is that all pipes in a Standard Dimensional Ratio have the same pressure rating.

For example, a polypropylene pipe with an SDR equal to 11 has a pressure rating of 150 psi. This pressure rating of 150 psi is consistent in all sizes of the system. A 1/2" SDR 11 and a 10" SDR 11 pipe and fitting have the same pressure rating. This is not the case in schedule systems. The wall thickness requirement in a schedule system is not based on material properties, so a 4" plastic pipe in Sch 80 will have a different pressure rating than a 10" Sch 80 pipe.

It should be noted that in all SDR systems the determined allowed pressure rating is based on the material properties. Therefore, the actual SDR number will be consistent within a material type, but not consistent across different materials of pipe.

Table C-1. Example of SDRs

Material	150 psi	230 psi
Polypropylene	SDR 11	SDR 7
PVDF	SDR 33	SDR 21

All material ratings are indicated in Asahi/America literature, drawings, price sheets, and on the product itself. For more information on SDR, contact Asahi/America's Engineering Department.

FLUID DYNAMICS

Sizing a thermoplastic pipe system is not much different than that of a metal pipe system. Systems transporting compressible fluids and non-compressible fluids are sized very differently and have different concerns. This section will approach each subject separately.

Non-Compressible Fluids

The basic definition for the liquid flow of any liquid is as follows:

$$\Delta P = \frac{\rho \Delta h}{144} = \frac{\Delta h \times (SG)}{2.31} \quad (C-4)$$

Basic definitions for fluid flow:

For liquid:

Where: ρ = fluid density, (lb/ft³)
 Δh = head loss, (ft)
 SG = specific gravity = $\rho/62.4$
 ΔP = pressure loss in psi

$$h_p = \frac{P}{\rho} = \text{pressure head (ft)} \quad (C-5)$$

$$h_v = \frac{v^2}{2g} = \text{velocity head (ft)} \quad (C-6)$$

For water:

Where: v = fluid velocity (ft/s)
 g = gravitational acceleration
 (32.174 ft/s²)

$$hg = z = \text{gravitational head} \quad (C-7)$$

= 32.174 ft

Sizing a Thermoplastic Piping System

Preliminary Sizing

The first step in designing a piping system is to decide what diameter sizes to use. If the only basis to begin with is the required flow rates of the fluid to be handled, there must be some way to estimate the diameter sizes of the piping. Without this knowledge, it would be a lengthy trial and error process. The diameter must first be known to calculate velocities and thus the pressure drop across the system. Once the pressure drop is found, a pump can be sized to provide the proper flow rate at the required pressure. Equations C-8, C-9, and C-10 represent quick sizing methods for liquid flow to give an initial sizing of diameter size of a piping system.

$$v = \frac{48}{(\rho)^{\frac{1}{3}}} \quad (C-8)$$

To determine maximum velocity for clear liquids:

Where: v = velocity (ft/s)
 ρ = fluid density, (lb/ft³)

Liquid Service

When sizing for erosive or corrosive liquids, Equation C-8 should be halved. The corresponding minimum diameters for liquid service can be estimated from the following equations:

Clear liquids: $d = 1.03 \frac{w^{\frac{1}{2}}}{\rho^{\frac{1}{3}}} \quad (C-9)$

Corrosive or erosive liquids:

$$d = 1.475 \frac{w^{\frac{1}{2}}}{\rho^{\frac{1}{3}}} \quad (C-10)$$

Where: w = flow rate (1000 lb/h)
 d = piping inside diameter (in)
 ρ = fluid density (lb/ft³)

Equations C-8, C-9, and C-10 represent the maximum velocity and minimum diameter that should be used in a piping system. To determine typical velocities and diameters, the following equations can be used to determine a starting point for these values:

Typical velocities: $v = 5.6 d^{0.304} \quad (C-11)$

Typical diameters, pressure piping:

$$d = 2.607 \left(\frac{w}{\rho} \right)^{0.434} \quad (C-12)$$

Suction or drain piping:

$$d = 3.522 \left(\frac{w}{\rho} \right)^{0.434} \quad (C-13)$$

Determination of Reynolds' Number

Once the diameter sizes have been selected for a given piping system, the next step is to determine whether the flow through the pipes is laminar or turbulent. The only accepted way of determining this characteristic through analytic means is by calculating the Reynolds' Number. The Reynolds' Number is a dimensionless ratio developed by Osborn Reynolds, which relates inertial forces to viscous forces.

To determine type of flow from Reynolds' Number value, use Equation C-14:

$$N_{re} = \frac{D_e v \rho}{\mu g} = \frac{D_e G}{\mu} = \frac{D_e v}{\Omega} \quad (C-14)$$

Where: N_{re} = Reynolds' Number (dimensionless)
 D_e = equivalent diameter (ft) = (inside diameter fully-filled circular pipe)
 v = velocity (ft/s)
 ρ = fluid density (lb/ft³)
 μ = relative viscosity (lb x sec/ft²)
 g = gravitational acceleration = (32.174 ft/s²)
 G = mass flow rate per unit area (lb/h-ft²)
 Ω = ratio of specific heats (dimensionless)

Laminar flow: $N_{re} < 2100$
 Transition region: $2100 < N_{re} < 3000$
 Turbulent flow: $N_{re} > 3000$

Once the Reynolds' Number is determined, it can be used in other equations for friction and pressure losses.

Pressure Loss Calculations

There are a number of different methods for calculating pressure loss in a piping system. Two of the more common methods are the Darcy method and the Hazen and Williams method. The Hazen and Williams method has been the more commonly accepted method for calculating pressure loss in plastic pipes. However, the Darcy method is the more universally accepted method for piping made of all materials, although its use requires more tedious calculations. Below is an explanation of both methods.

Darcy Method

The Darcy formula states that the pressure drop is proportional to the square of the velocity, the length of the pipe, and is inversely proportional to the diameter of the pipe. The formula is valid for laminar or turbulent flow. Expressed in feet of fluid flowing, the Darcy formula is:

$$h_f = \frac{f L v^2}{2 d g} \quad (C-15)$$

Where: h_f = head loss due to friction (ft)
 f = Darcy (Moody) friction factor
 L = total length of pipe, including equivalent lengths of fittings, valves, expansions, and contractions, etc. (ft)
 v = fluid velocity (ft/sec)
 d = inside diameter (ft)
 g = gravitational acceleration (32.174 ft/s²)

The Darcy method expressed to determine pressure drop:

$$\Delta P = \frac{\rho f L v^2}{144 d 2g} \quad (C-16)$$

Where: ΔP = pressure loss due to friction (psi)
 ρ = fluid density (lb/ft³)

The equation is based upon the friction factor (f), which in this form is represented as the Darcy or Moody friction factor. The following relationship should be kept in mind, as it can be a source of confusion:

$$f_{DARCY} = f_{MOODY} = 4f_{FANNING}$$

In Perry's *Handbook of Chemical Engineering*, and other chemical and/or mechanical engineering texts, the Fanning friction factor is used, so this relationship is important to point out. If the flow is laminar ($N_{re} < 2000$), the friction factor is:

$$f = \frac{64}{N_{re}} \quad (\text{laminar flow only}) \quad (C-17)$$

If this quantity is substituted into Equation C-16, the pressure drop becomes the Poiseuille equation for pressure drop due to laminar flow:

$$\Delta P = 0.000668 \frac{\mu L v}{d^2} \quad (\text{laminar flow only}) \quad (C-18)$$

If the flow is turbulent, as is often the case for plastic pipes, the friction factor is not only a factor of Reynolds' Number, but also upon the relative roughness (ϵ/d). (ϵ/d) is a dimensionless quantity representing the ratio of roughness of the pipe walls, ϵ , and the inside diameter, d . Since Asahi/America's thermo-plastic systems are extremely smooth, friction factor decreases rapidly with increasing Reynolds' Number. The roughness has a greater effect on smaller diameter pipes since roughness is independent of the diameter of the pipes.

This relationship can be seen graphically in Figure C-1. (Note: ϵ has been determined experimentally to be 6.6×10^{-7} ft for PVDF. ϵ for polypropylene pipe is approximately the same as that for drawn tubing = 5×10^{-6} ft) The friction factor can be found from the plot of ϵ/d versus friction factor shown in Figure C-2, which is known as the Moody chart. The Moody chart is based on the Colebrook and White equation:

$$\frac{1}{(f)^{1/2}} = -2 \log \frac{\epsilon}{3.7 d} + \frac{2.51}{N_{re}(f)^{1/2}} \quad (C-19)$$

This equation is difficult to solve, since it is implicit in f, requiring a designer to use trial and error to determine the value.



Hazen and Williams Method

The Hazen and Williams formula is valid for turbulent flow and usually provides a sound, conservative design basis for plastic piping sizing. The formula, simply stated is:

$$h_f = 0.2083 \left(\frac{100}{C} \right)^{1.85} \times \left(\frac{Q}{d} \right)^{4.87} \quad (C-20)$$

Where: h_f = friction head (ft of water/100 ft of pipe)
 d = inside diameter of pipe (ft)
 Q = flow rate (gpm)
 C = roughness constant

To determine pressure loss in psi:

$$\Delta P = 0.4335 h_f \quad (C-21)$$

Where: ΔP = pressure loss (psi/100 ft of pipe)

For plastic piping, it has been generally accepted that C varies from 165 to 150. Therefore, most designs have been sized using $C = 150$ as the basis, providing a conservative design. This compares quite favorably with that of carbon steel, which generally is assigned a value of $C = 120$ for new pipe and $C = 65$ for used piping. Substituting $C = 150$ into Equation C-20 yields the following relationship in Equation C-22:

$$h_f = 0.0983 \frac{Q^{1.85}}{d^{4.87}} \quad (\text{for } C = 150) \quad (C-22)$$

Asahi/America has already calculated the pressure drop in our pipe systems at most flow rates using the Hazen and Williams method. These tables are found by material in Appendix A.

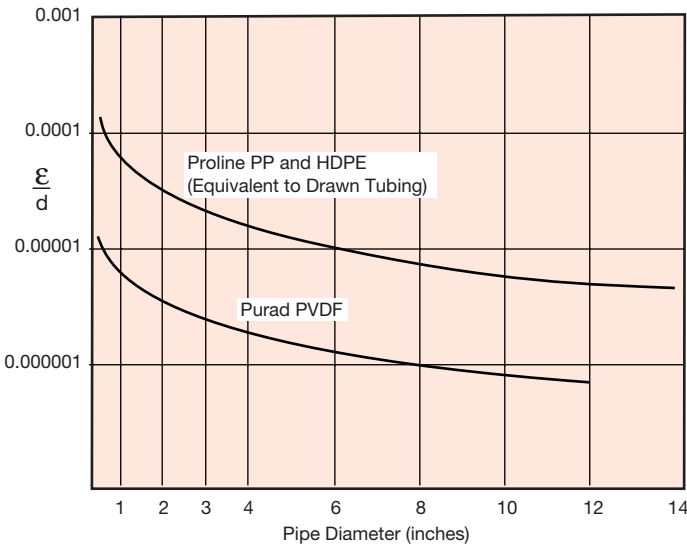

Figure C-1. Relative roughness of Asahi/America pipe

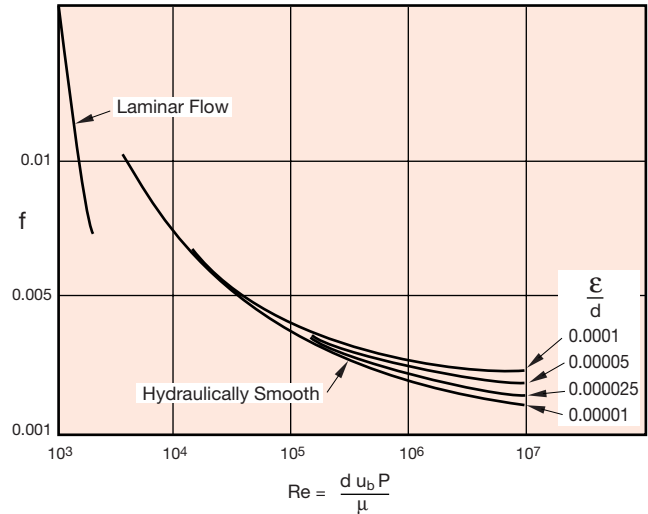

Figure C-2. Friction factor versus Reynolds' Number for Asahi/America pipe

Quick Sizing Method for Pipe Diameters

By modifying the Darcy equation, it can be seen that pressure loss is inversely proportional to the fifth power of the internal diameter. The same is approximately true for the Hazen and Williams formula as shown in Equation C-22. Therefore, when pressure drop has been determined for one diameter in any prescribed piping system, it is possible to prorate to other diameters by ratio of the fifth powers. The following relationship is used to prorate these diameters when the Darcy formula has been used in Equation C-23:

$$\Delta P_2 = \Delta P_1 \frac{d_1^5}{d_2^5} \quad (C-23)$$

Where: ΔP_1 = pressure drop of 1st diameter, psi
 ΔP_2 = pressure drop for new diameter, psi
 d_1 = 1st diameter selected (in)
 d_2 = new diameter selected (in)

This formula assumes negligible variation in frictional losses through small changes in diameter sizes, and constant fluid density, pipe length, and fluid flow rate. When using Hazen and Williams, the formula itself is easy enough to use if the value of C is considered to be constant and is known.

Calculating System Pressure Drop

For a simplified approach to calculating pressure drop across an entire pressure piping system consisting of pipe, fittings, valves, and welds, use the following equation:

$$\Delta P_{total} = \Delta P_{pipe} + \Delta P_{fittings} + \Delta P_{valves} + \Delta P_{welds} \quad (C-24)$$

Pressure Drop for Pipe

To determine the pressure drop due to the pipe alone, use one of the methods already described or Equation C-25.

$$\Delta P_{pipe} = \frac{\lambda}{144} \times \frac{L}{d} \times \frac{S G v^2}{2 g} \quad (C-25)$$

- Where: λ = frictional index, 0.02 is sufficient for most plastic pipe
- L = pipe length (ft)
- d = inside pipe diameter (ft)
- SG = specific gravity of fluid (lb/ft³)
- v = flow velocity (ft/s)
- g = gravitational acceleration (32.174 ft/s²)

Pressure Drop for Fittings

To determine pressure drop in fittings, use Equation C-26.

$$\Delta P_{fittings} = \frac{\epsilon}{144} \times \frac{v^2}{2g} \quad (C-26)$$

where: ϵ = resistance coefficient of the fitting.

Table C-2. ϵ Resistance Coefficient (by fitting)

Size	Std 90	Ext Lg 90	45	Tee
1/2" (20 mm)	1.5	2.0	0.3	1.5
1" (32 mm)	1.0	1.7	0.3	1.5
1 1/2" (50 mm)	0.6	1.1	0.3	1.5
≥2" (63 mm)	0.5	0.8	0.3	1.5

Pressure Drop for Valves

To determine the pressure drop across a valve requires the Cv value for the valve at the particular degree of open. The Cv value is readily available from a valve manufacturer on each style of valve.

Use Equation C-27 to determine the pressure drop across each valve in the pipe system. Sum all the pressure drops of all the valves.

$$\Delta P_{valves} = \frac{Q^2}{C_v^2} \cdot SG \quad (C-27)$$

Pressure Drop for Welds

Finally, determine the pressure drop due to the welding system. In actuality it would be very difficult and time consuming to determine the pressure drop across each weld in a system.

Therefore, a rule of thumb of 3 to 5% of pressure loss across a system can be used to compensate for the welding effects.

Table C-3 shows pressure drop % by various welding systems.

Table C-3. Pressure Drop for Various Welding Systems

Size (inches)	Butt/IR	HPF	Socket
1/2 - 1 1/4	5.0%	0%	8%
1 1/2 - 2 1/2	3.0%	0%	6%
3 - 4	2.0%	—	4%
6	1.5%	—	—
8	1.0%	—	—
10 - 12	0.5%	—	—

Outlet Piping for Pumps, Pressure Tanks, or Reservoirs

When piping is used to convey pressurized liquids, and a pump is used to supply these liquids, the pump outlet pressure can be found by making an energy balance. This energy balance is defined by the Bernoulli equation:

$$Z_1 + p_1 \bar{v}_1 + \frac{v_1^2}{2g} = h_{pump} + h_f + p_2 \bar{v}_2 + \frac{v_2^2}{2g} + Z_2 \quad (C-28)$$

- Where: Z_1, Z_2 = elevation at points 1 and 2 (ft)
- P_1, P_2 = pressure in system at points 1 and 2 (psi)
- v_1, v_2 = average velocity at points 1 and 2 (ft/lb)
- $\bar{v}_1, \bar{v}_2 = \frac{1}{\rho} =$ specific volume at points 1 and 2 (ft³/lb)
- h_f = frictional head losses (ft)
- h_{pump} = pump head (ft)

Note: This balance is simplified to assume the following: constant flow rate, adiabatic (heat loss = 0), isothermal (constant temp.), low frictional system.

Once frictional losses in the piping are known along with elevational changes, the pump head can be calculated and the pump sized. If a pump already exists, then an analysis can be made from the h_f value to determine which diameter size will give frictional losses low enough to allow the pump to still deliver the fluid.

It may occur that the application does not involve pumps at all, but instead involves gravity flow from an elevated tank, or flow from a pressurized vessel. In either case, Equation C-28 can be solved with the term $h_{pump} = 0$ to determine elevation necessary of the reservoir to convey the fluid within a given diameter size, or calculate the amount of pressure required in the pressure tank for the given diameter size. If the application is such that a pressure tank or elevation of reservoir is already set, then h_f can be solved to determine diameter size required to allow the fluid to be delivered.



Inlet Piping to Pumps

Inlet sizing of diameters of piping to supply a pump depends on the Net Positive Suction Head (NPSH) required by the pump. NPSH is given by the manufacturer of a pump for each specific pump to be supplied. If the pressure at the entrance to the pump is less than the NPSH, a situation known as cavitation will occur. Cavitation will occur at pump inlets whenever the fluid pressure drops below the vapor pressure at the operating temperature. As the pump “sucks” too hard at the incoming fluid, the fluid will tend to pull apart and vaporize, resulting in a subsequent damaging implosion at the impeller face. In addition, NPSH must be higher than the expected internal loss between the pump and impeller blades. To determine NPSH, the following equation is used:

$$\text{NPSH} = h_{\text{atmos}} + Z_{\text{pump}} - h_{\text{friction}} - h_{\text{minor}} - h_{\text{vapor}} \quad (\text{Z is positive if the pump is below inlet}) \quad (\text{C-29})$$

- Where:
- h_{atmos} = atmospheric pressure head
= $(p_a/62.4)$; p_a is in lb/ft² (ft)
(corrected for elevation)
 - Z_{pump} = elevation pressure head (ft)
(difference between reservoir exit and pump inlet)
 - h_f = total of pipe fittings and valve frictional head losses (ft)
 - h_{minor} = entrance and/or exit losses (ft),
(use inlet loss formulas or $h_c = 0.0078v^2$)
 - h_{vapor} = vapor head (ft), (use property tables for specific fluid, i.e., steam tables for H₂O)

To determine diameter of piping required to supply the minimum NPSH, the following procedure is outlined.

Step 1.

Obtain the minimum NPSH at the pump inlet from the pump specifications.

Step 2.

Calculate h_{atmos} , Z_{pump} , h_{minor} , and h_{vapor} .

Step 3.

Determine h_f by subtracting items in Step 2 from NPSH in Step 1.

Step 4.

Determine minimum inside diameter by rearranging Equation C-20. The resulting equation for d follows.

$$d = \left[\frac{0.2083 \left(\frac{100}{C} \right)^{1.85} \times Q^{1.85}}{h_f} \right]^{0.205} \quad (\text{C-30})$$

Compound Pipe Sizing

Flow through a network of two or more parallel pipes connected at each end is proportional to the internal diameters, and lengths of the parallel legs, for constant friction factors (coefficients) and turbulent flow. The following relationships will be true:

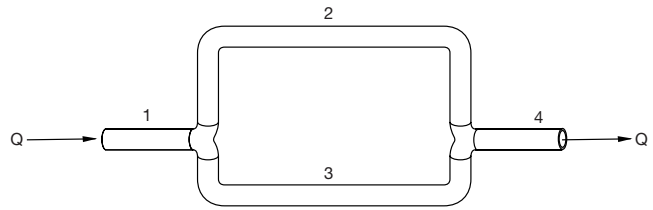

Figure C-3. Typical compound pipe

$$R = \frac{Q_3}{Q_2} \quad (\text{C-31})$$

- Where:
- Q_3 = flow rate in leg 3 (gpm)
 - Q_2 = flow rate in leg 2 (gpm)
 - R = ratio of total flow, Q , through compound network
 - l_2 = length of leg 2
 - l_3 = length of leg 3

And:

$$R = \left[\left(\frac{l_2}{l_3} \right) \left(\frac{d_3}{d_2} \right)^5 \right]^{\frac{1}{2}} \quad (\text{C-32})$$

Or:

$$R = \left[\left(\frac{l_2}{l_3} \right)^{1.08} \left(\frac{d_3}{d_2} \right)^{5.26} \right]^{\frac{1}{2}} \quad (\text{C-33})$$

Equation C-32 is used when using the Darcy equation and Equation C-33 is used when using Hazen-Williams to determine velocities in legs. For other velocities, use Equation C-34.

$$v_2 = \frac{q_2}{448.8 A_2} ; v_3 = \frac{q_3}{448.8 A_3} \quad (\text{C-34})$$

- Where:
- v_2 = velocity in leg 2 (ft/s)
 - v_3 = velocity in leg 3 (ft/s)
 - A_2 = cross-sectional area in leg 2 (ft²)
 - A_3 = cross-sectional area in leg 3 (ft²)

448.8 is derived from (60 sec/min) x (7.48 gal/ft³)

Since total head loss is the same across each parallel leg, total head loss can be calculated by:

$$h_f = h_1 + h_2 + h_4 = h_1 + h_3 + h_4 \quad (C-35)$$

Where: h_f = total head loss through entire piping system (ft)

Sizing of Drain, Waste, and Vent Piping

Flow in a Vertical Stack

As flow in a vertical stack is accelerated downward by the action of gravity, it assumes the form of a sheet around the pipe wall shortly after it enters the sanitary tee or wye. The acceleration of the sheet continues until the frictional force exerted by the walls of the stack equals the force of gravity. The maximum velocity that is thus attained is termed “terminal velocity” and the distance required to achieve this velocity is termed “terminal length.” It takes approximately one story height for this velocity to be attained. The terminal velocity normally falls into the range of somewhere between 10 to 15 feet per second. Some simplified equations for terminal velocity and terminal length are as follows:

$$V_T = 3 \left(\frac{Q}{d} \right)^{0.4} \quad (C-36)$$

$$L_T = 0.052(V_T)^2 \quad (C-37)$$

Where: V_T = terminal velocity in stack (ft/s)
 L_T = terminal length below entry point (ft)
 Q = flow rate (gpm)
 d = inside diameter of stack (ft)

When flow in the stack enters the horizontally sloping building drain at the bottom of the stack, the velocity is slowed from the terminal velocity. The velocity in the horizontally sloping drain decreases slowly and the depth of flow increases. This continues until the depth increases suddenly and completely fills the cross section of the sloping drain. The point at which this occurs is known as hydraulic jump. The pipe will then flow full until pipe friction along the walls establishes a uniform flow condition of the draining fluid. The distance at which jump occurs varies considerably according to flow conditions, and the amount of jump varies inversely with the diameter of the horizontal building drain.

Flow capacity of the vertical stack depends on the diameter of the stack and the ratio of the sheet of fluid at terminal velocity to the diameter of the stack:

$$Q = 27.8 (r_s)^{1.67} (d)^{2.67} \quad (C-38)$$

Where: Q = capacity of the stack (gpm)

r_s = ratio of cross-sectional area of the fluid at terminal velocity to internal diameter of the stack

d = inside diameter (in)

The value of r_s is determined according to local building codes. Also, the maximum number of fixture units, laboratory drains, floor drains, etc. is normally established by the local building codes.

Flow in Sloping Drains Where Steady Uniform Flow Exists

There are many formulas useful to determine flow for sloping drains with steady uniform flow. The most commonly used equation is the Manning equation:

$$\bar{v} = \frac{1.486R^{0.67} S^{0.5}}{n} \quad (C-39)$$

Where: \bar{v} = mean velocity (ft/s)
 R = hydraulic radius = area flowing/wetted perimeter (ft)
 S = hydraulic gradient (slope)
 n = Manning coefficient

The value of n varies from 0.012 for 1 1/2" pipe to 0.016 for pipes 8" and larger under water flow. The quantity of flow is found from:

$$Q = Av \quad (C-40)$$

Where: Q = flow rate (ft³/s)
 A = cross section of the flow (ft²)
 v = velocity (ft/s)

This equation is not valid for conditions where surging flow might exist. A more detailed analysis should be used in surging flow situations, with the Manning equation serving as a rough check on the calculated values.

Compressible Fluids

Designing pipe lines for compressed air or gas is considerably different from designing a non-compressible liquid system. Gases are compressible, so there are more variables to consider. Designs should take into account current and future demands to avoid unnecessarily large pressure drops as a system is expanded. Elevated pressure drops represent unrecoverable energy and financial losses.

Main Lines

Normal compressed air systems incorporate two types of pipe lines when designed correctly: the main (or the trunk) line and the branch lines. Mains are used to carry the bulk of the compressed gas. Undersizing the main can create large pressure drops and high velocities throughout the system. In general, systems should be oversized to allow for future expansion, as well as reduce demand on the compressor.

Oversizing the main line will be more of an initial capital expense, but can prove to be an advantage over time. In addition to reducing pressure drop, the extra volume in the trunk line acts as an added receiver, reducing compressor demand and allows for future expansion. Small mains with high velocities can also cause problems with condensed water. High air velocities pick up the condensed water and spray it through the line. With a larger diameter, velocities are lowered, allowing water to collect on the bottom of the pipe while air flows over the top. A generally accepted value for velocity in the main line is 20 feet per second. It may also be preferred to arrange the mains in a loop to have the entire pipe act a reservoir.

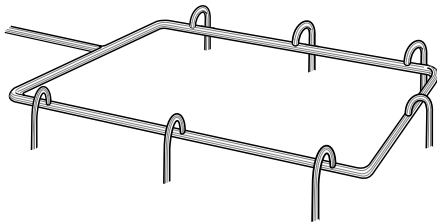

Figure C-4. Main compressed air loop with branches

To design the main line of a compressed gas system, the following equation has been developed:

$$d = \left(\frac{0.00067 L Q^{1.85}}{\Delta P P} \right)^{0.2} \quad (C-41)$$

Where: d = inside diameter (inches)
 L = length of main line (ft)
 Q = standard volumetric flow rate (make-up air)
 P = output pressure from compressor (psi)
 ΔP = allowable pressure drop (psi)

Equation C-41 relates the pipe's inside diameter (id) to the pressure drop. In order to use the equation, certain information must be known. First, the required air consumption must be predetermined. Based on required air consumption, choose a compressor with an output pressure rating (P). The length of the main pipe line to be installed and the number of fittings in the main line must also be known. For fittings use Appendix A to determine the equivalent length of pipe per fitting style. Specify the allowable pressure drop in the system. Typically, a value of 4 psi or less is used as a general rule of thumb for compressed air systems.

Branch Lines

Lines of 100 feet or less coming off the main line are referred to as branch lines. Since these lines are relatively short in length, and the water from condensation is separated in the main lines, branches are generally sized smaller and allow for higher velocities and pressure drops.

To prevent water from entering the branch line, gooseneck fittings are used to draw air from the top of the main line, leaving condensed water on the bottom of the main.

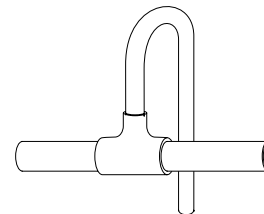

Figure C-5. Gooseneck fitting

THERMAL EXPANSION DESIGN

Plastic pipe systems will expand and contract with changing temperature conditions. It is the rule and not the exception. The effect of thermal expansion must be considered and designed for in each and every thermoplastic pipe system. Thermal effects in plastic versus metal are quite dramatic. To illustrate the point, Figure C-6 below outlines the differences in growth rates between different plastics and metal piping materials.

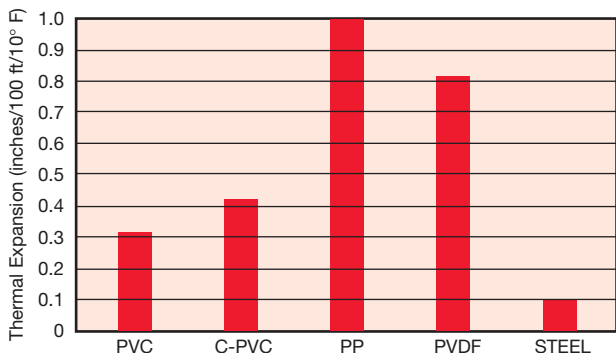

Figure C-6. Comparison of thermal expansion of plastic and steel piping material

An increase in temperature in a system will cause the pipe to want to expand. If the system is locked in position and not allowed to expand, stress in the system will increase. If the stress exceeds the allowable stress the system can tolerate, the piping will fatigue and eventually could fail.

Progressive deformation may occur upon repeated thermal cycling or on prolonged exposure to elevated temperature in a restrained system. Thermoplastic systems, therefore, require sufficient flexibility to prevent the expansion and contraction from causing:

- Failure of piping or supports from over strain or fatigue
- Leakage
- Detrimental stresses or distortion in piping or connected equipment

Asahi/America has put together simplified equations to predict the stress in a system to avoid fatigue. For safety reasons, Asahi/America takes a conservative approach to design considerations. With over 5,000 successful installations of thermoplastic piping systems, Asahi/America is providing the right approach.

Many of the equations below are applicable for single and double wall piping systems. A dual contained piping system will have a few more design variables, but the approach is similar. Review the single wall section first to fully comprehend thermal expansion design issues.

THERMAL EXPANSION AND CONTRACTION IN SINGLE WALL PIPING SYSTEMS

First, calculate the stress that will be present in the system due to all operating systems. These include stresses due to thermal cycling and the stress due to internal pressure.

Thermal stress can be calculated with Equation C-42.

$$S_T = E \alpha \Delta T \tag{C-42}$$

Where: S_T = thermal stress (psi)
 E = modulus of elasticity (psi)
 α = coefficient of thermal expansion in/in ° F
 ΔT = ($T_{max} - T_{install}$) (° F)

Next calculate the stress due to internal pressure.

$$S_p = P \frac{(D-t)}{2t} \tag{C-43}$$

Where: S_p = internal pressure stress (psi)
 D = pipe OD (in)
 t = wall thickness (in)
 P = system pressure (psi)

Now combine the stresses of S_T and S_p using Equation C-44 to obtain the total stress placed on the system due to the operating parameters.

$$S_c = \sqrt{S_T^2 + S_p^2} \tag{C-44}$$

Where: S_c = combined stress (psi)

Having the combined stress of the system, the total end load on the piping and anchors can be calculated using Equation C-45.

$$F = S_c A \tag{C-45}$$

Where: F = end Load (lbs)
 S_c = combined stress (psi)
 A = cross-sectional area of pipe wall (in²)

Knowing the combined stress and force generated in a system now allows the designer to make decisions on how to compensate for the thermal effects.

By comparing the combined stress to the hoop stress of material allows a safety factor to be determined.

EXAMPLE

A PVDF single wall pipe system with a combined stress of 500 psi is compared to the hoop stress or allowable stress of PVDF, which is 1100 psi with all the appropriate safety (HDB = 2200 psi, $S = HDB/2 = 1100$ psi) factors:

$$SF = 1100 \text{ psi} / 500 \text{ psi} = 2.2$$

Therefore if this system was fully restrained, it would have 2.2 to 1 safety factor. The factor assumes that the system will be properly anchored and guided to avoid pinpoint loads.

If the value of the combined stress was 600 psi and the resulting safety factor is now below 2, the designer should/may choose to compensate for the expansion using a flexible design.

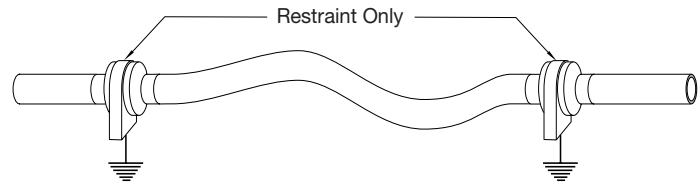

Figure C-9. Improper design

Flexible System Design

A flexible pipe design is based on strategically using expansion and contraction compensating devices to relieve the stress in the piping system. Common devices are, but are not limited to:

- Expansion loops
- Expansion offsets
- Changes in direction
- Flexible bellows
- Pipe pistons

To compensate for thermal expansion, Asahi/America recommends using loops, offsets, and changes in direction. By using the pipe itself to relieve the stress, the integrity of the pipe system is maintained. The use of bellows or pistons will also work, but often introduce other concerns such as mechanical connections and possible leaky seals. Although these occurrences are not common, using the pipe eliminates the chance altogether.

The following section outlines how to size expansion loops. An example is included to better understand how to use the equations and lay out a system.

To start, first determine the amount of growth in the pipe system due to the temperature change. The change in pipe length is calculated as follows:

$$\Delta L = 12 \times L \times \alpha \times \Delta T \quad (C-46)$$

- Where:
- ΔL = change in length (in)
 - L = length of the pipe run (ft)
 - α = coefficient of thermal expansion (in/in/° F)
 - $\alpha = 6.67 \times 10^{-5}$ for PVDF
 - $\alpha = 8.33 \times 10^{-5}$ for PP
 - $\alpha = 8.33 \times 10^{-5}$ for HDPE
 - ΔT = temperature change (° F)

ΔT is the maximum temperature (or minimum) minus the install temperature. If the installation temperature or time of year is unknown, it is practical to increase the ΔT by 15% for safety. It is not necessary or practical to use the maximum temperature minus the minimum temperature unless it will truly be installed in one of those conditions.

Restraining a System

If a system design is deemed safe to restrain, proper hanging design becomes critical. If fittings such as 90° elbows are not properly protected, the thermal end load could crush the fitting. It is important to remember that end load is independent of pipe length. The expansion in one foot of piping compared to the expansion in 100 feet of piping under the same operating conditions will generate the same force.

A proper design will protect fittings using anchors and guides. Use guides to keep pipe straight and not allow the material to bow or warp on the pipe rack. Use anchor or restraint style fittings to protect fittings at changes of direction or branches.

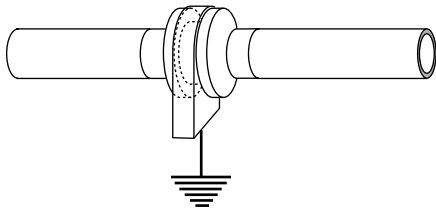

Figure C-7. Restraint fitting and hanger

Finally, ensure proper hanging distances are used based on the actual operating temperature of the system.

Figures C-8 and C-9 are illustrations of proper and improper design and installation hanging techniques.

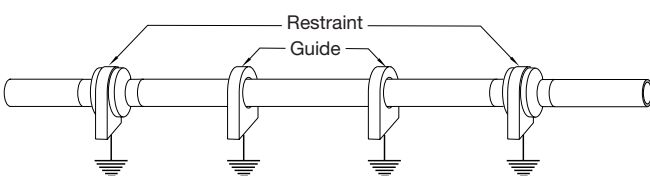

Figure C-8. Proper design

EXAMPLE

A 3" SDR 11 (150 psi) PP pipe system running up a wall 10 feet from a pump. It then runs 25 feet north by 100 feet east to an existing tank. The system will be installed at about 60° F and will see a maximum temperature in the summer of 115° F. See Figure C-10 and following equation for calculating the expansion for the 25-foot run and the 100-foot run.

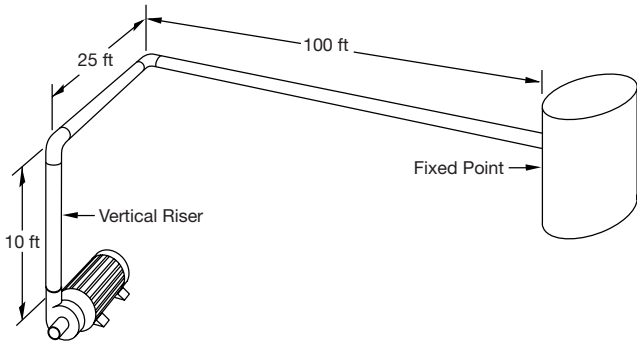

Figure C-10. Sample layout

For the 100-foot run:

$$L = 12 (100)(8.33 \times 10^{-5})(115-60)$$

$$\Delta L = 5.50 \text{ inches}$$

Using the same procedure we now determine the growth on the 25-foot run.

$$\Delta L = 1.40 \text{ inches}$$

After determining the amount of expansion, the size of the expansion/contraction device can be determined. The use of loops, offsets, or existing changes in directions can be used in any combination to accommodate for the expansion. To determine the length and width of an expansion loop, use Equation C-47.

$$A = C\sqrt{D\Delta L} \tag{C-47}$$

- Where:
- A = loop length (in)
 - C = constant
 - = 20 for PVDF
 - = 30 for PP, PE
 - D = pipe OD (in)
 - ΔL = change in length (in)

The loop width is the length A divided by 2. Figure C-11 illustrates a typical loop.

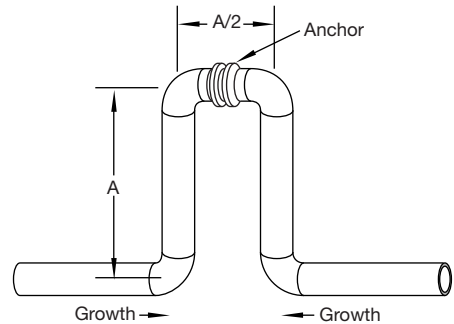

Figure C-11. Loop

An offset can be calculated in the same manner using Equation C-48. Figure C-12 depicts a typical offset used to accommodate for thermal expansion.

$$A = C\sqrt{2 D \Delta L} \tag{C-48}$$

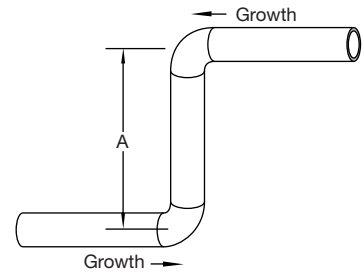

Figure C-12. Offset

The last choice is to accommodate the expansion using existing changes in direction. By allowing pipe to flex at the corners, stress can be relieved without building large expansion loops.

For a change in direction to properly relieve stress, it must not be locked for a certain distance allowing the turn to flex back and forth. Use Equation C-49 and Figure C-13 to properly design changes in direction.

$$A = C\sqrt{D\Delta L} \quad (C-49)$$

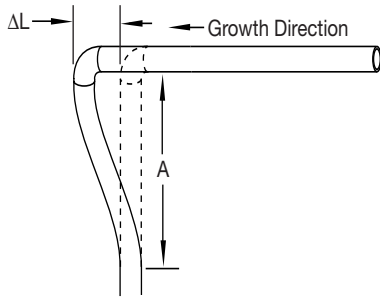

Figure C-13. Changes in direction

The distance A is the amount of distance required prior to placing an anchor on the pipe from the elbow. By leaving the distance "A" free floating, the pipe can expand and contract freely to eliminate stress on the system. Within the distance A, it is still required to support the pipe according to the standard support spacing, but without fixing it tightly. Since the pipe will be moving back and forth, it is important to ensure the support surface is smooth and free of sharp edges that could damage the pipe.

EXAMPLE

Consider two possible approaches to solve the expansion in the system. For the shorter run of 25 feet, use the change in direction to compensate for the growth. For the longer 100 feet, use an expansion loop in the middle of the run.

First consider the expansion loop. Calculate the length of the loop's legs as follows:

$$A = C\sqrt{D\Delta L}$$

$$A = 30\sqrt{3.5 \times 5.50}$$

$$A = 132 \text{ inches} = 11 \text{ feet}$$

$$A / 2 = 5.5 \text{ feet}$$

The 25-foot long run must still be considered. Since the 100-foot pipe run is anchored on the end of the pipe system, it is difficult to use the horizontal change in direction to compensate for the growth. However, the 90° elbow on the end of the vertical can be used.

EXAMPLE

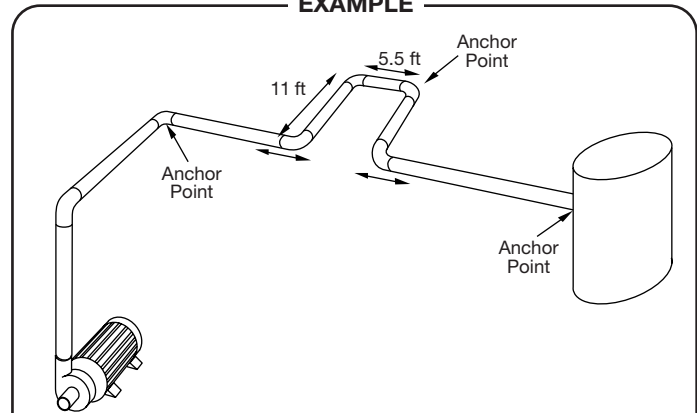

Figure C-14. In-line expansion loop

Figure C-15 is an elevation view of how the change in direction can be used.

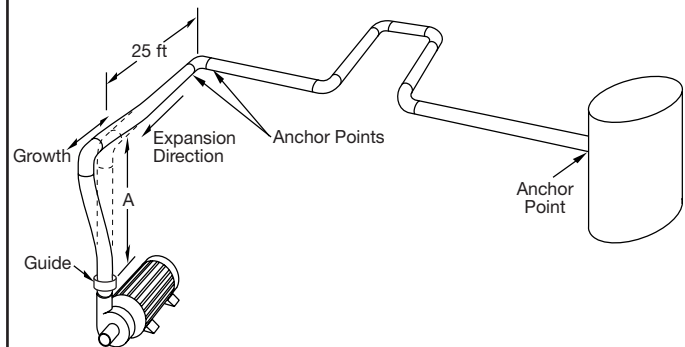

Figure C-15. Use of change in direction

The distance A is the length of pipe on the vertical run that must be flexible to compensate for the growth. A is calculated as follows:

$$A = C\sqrt{D\Delta L}$$

$$A = 30\sqrt{3.54 \times 1.40}$$

$$A = 66.7 \text{ inches} = 5.5 \text{ feet}$$

Therefore, the vertical run should be guided 5.5 feet from the bottom of the horizontal run. This allows the expansion to relax itself by use of the flexible 90° elbow.

As with all three methods of expansion, it is necessary to use hangers that will anchor the pipe in certain locations and be a guide in other locations. Guides are extremely important to ensure that the expansion is eliminated within the compensating device and not by the pipe bowing or snaking. Also, restraint fittings are required at the point of anchoring. See *Hanging Practices* in this section.

THERMAL EXPANSION AND CONTRACTION IN DOUBLE WALL PIPING SYSTEMS

The effect of thermal changes on a double containment piping system is the same as a single wall system. However, the design considerations are more involved to ensure a safe operation.

C Duo-Pro and Fluid-Lok Systems

For thermal expansion in a double contained system, it is necessary to discuss and design it based on the system. Not all double wall piping can be designed in the same manner, and some systems truly may not be able to be designed around large changes in temperature.

In a double contained piping system, three types of expansion can occur:

- Carrier pipe exposed to thermal changes, containment remains constant. Typical possibility when carrier pipe is exposed to liquids of various temperature, while outer containment is in a constant environment such as in buried applications.
- Containment piping experiences thermal changes, while carrier remains constant. Typical application is outdoor pipe racking with constant temperature media being transported in carrier.
- Both inner and outer experience temperature changes.

A double containment system can be restrained the same way as a single wall system. The values for actual stress in a system versus those allowable can also be determined. Then, the decision can be made according to the system's needs to use either flexible or restrained supports.

Determining Stress

This method is the same for all types of double containment expansion.

First, calculate the stress that will be present in the system due to all operating systems. These include stresses due to thermal cycling and the stress due to internal pressure.

Thermal stress can be calculated with Equation C-50.

$$S_T = E \alpha \Delta T \quad (C-50)$$

Where: S_T = thermal stress (psi)
 E = modulus of elasticity (psi)
 α = coefficient of thermal expansion (in/in° F)
 ΔT = ($T_{max} - T_{install}$) (° F)

See Section B on *Materials* for the values of modulus of elasticity and coefficient of thermal expansion for each material.

Next, calculate the stress due to internal pressure.

$$S_p = P \frac{(D-t)}{2t} \quad (C-51)$$

Where: S_p = stress due to internal pressure (psi)
 D = pipe OD (in)
 t = wall thickness (in)
 P = system pressure (psi)

Now combine the stresses of S_p and S_T using Equation C-52 to obtain the total stress placed on the system due to the operating parameters.

$$S_c = \sqrt{S_T^2 + S_p^2} \quad (C-52)$$

Where: S_c = combined stress (psi)

Having the combined stress of the system, the total end load on the piping and anchors can be calculated using Equation C-53.

$$F = S_c A \quad (C-53)$$

Where: F = end load (lbs)
 S_c = combined stress (psi)
 A = area of pipe wall (in²)

Knowing the combined stress and force generated in a system now allows the designer to make decisions on how to compensate for the thermal effects.

By comparing the combined stress to the hoop stress of material allows a safety factor to be determined.

EXAMPLE

A PVDF carrier with a combined stress of 500 psi is compared to the hoop stress or allowable stress of PVDF, which is 1100 psi with all the appropriate safety (HDB = 2200 psi, $S = HDB/2 = 1100$ psi) factors:

$$SF = 1100 \text{ psi} / 500 \text{ psi} = 2.2:1$$

Therefore, if this system was fully restrained, it would have 2.2 to 1 safety factor. The factor assumes that the system will be properly anchored and guided to avoid pinpoint loads.

If the value of the combined stress was 600 psi and the resulting safety factor is now below 2, the designer should/may choose to compensate for the expansion using a flexible design.

Carrier Expansion, Containment Constant

Restraint Design

If a system design is deemed safe to be restrained, proper design and layout must be engineered to ensure the system functions properly.

First is the use of the Dogbone fitting, also known as a Force Transfer Coupling. In systems where thermal expansion is on the carrier pipe and the secondary piping is a constant temperature, the Dogbone fitting is used in order to anchor the inner pipe to the outer pipe. The Dogbone fitting is a patented design of Asahi/America making our system unique in its ability to be designed for thermal expansion effects.

Dogbones are available in annular and solid design. Annular Dogbones allow for the flow of fluid in the containment piping to keep flowing, while solid Dogbones are used to stop flow in the containment pipe and compartmentalize a system. Figure C-16 depicts a Dogbone fitting.

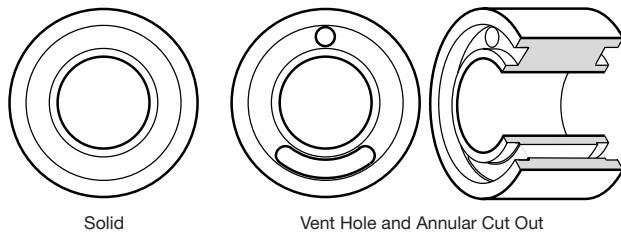

Figure C-16. Solid and flow through Dogbones

In a buried system, the outer wall pipe is continuously restrained. Welding the standard Dogbone restraint into the system fully anchors the pipe. In systems where the pipe is not buried, a special Dogbone with restraint shoulders is required to avoid stress from the carrier pipe to pull on the containment pipe. Below is a detail of a Dogbone with restraint shoulders.

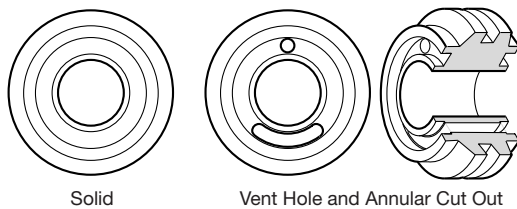

Figure C-17. Restraint shoulder Dogbones

Carrier Constant, Containment Expansion

Restraint Design

In systems where the containment pipe will see thermal expansion and the inner pipe is constant, and where it has been determined that the pipe can safely be restrained, the installation is simplified. Since the outer pipe will be locked into position and the inner pipe does not want to expand, the design is based on the secondary pipe only.

In these cases, only an outer wall anchor is required. However, since the pipe will most likely be joined using simultaneous butt fusion (where inner and outer welds are done at the same time), the restraint shoulder Dogbone is the logical choice for a restraint fitting.

Restrained Systems—General

If restraining a system, proper layout design becomes critical. If fittings such as 90° elbows are not properly protected, the thermal end load could crush the fitting. It is important to remember that end load is independent of pipe length. The expansion in one foot of piping compared to the expansion in 100 feet of piping under the same operating conditions will generate the same force.

A proper design will protect fittings using Dogbones and guides. Use guides to keep pipe straight and not allow the material to bow or warp on the pipe rack. In an underground system, the pipe will be naturally guided by use of trench and backfill. Use Dogbones to protect fittings at changes of direction or branches.

It is important to note that Duo-Pro and Fluid-Lok systems use support discs on the end of pipe and fittings to ensure proper centering of the components. These support discs are designed to be centering guides and locks for fusion. The support disc is not an anchor fitting.

Finally, ensure the proper hanging distances are used based on the actual operating temperature of the system. Figures C-18 and C-19 are illustrations of proper and improper design and installations to highlight the importance of proper hanging techniques.



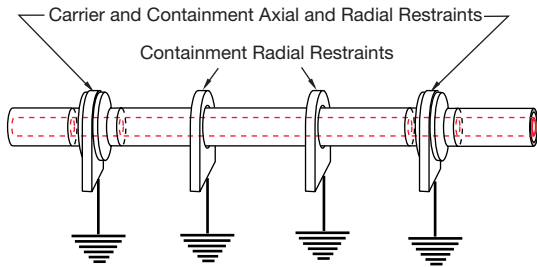

Figure C-18. Proper design



Figure C-19. Improper design

Flexible System Design — General

A flexible double containment system requires additional design work to ensure safe working operation.

A flexible pipe design is based on strategically using expansion and contraction compensating devices to relieve the stress in the piping system. Common devices are, but are not limited to:

- Expansion loops
- Expansion offsets
- Changes in direction
- Flexible bellows
- Pipe pistons

Asahi/America recommends compensating for thermal expansion by using loops, offsets, and changes in direction. By using the pipe itself to relieve the stress, the integrity of the pipe system is maintained. The use of bellows or pistons will also work, but often introduce other concerns such as mechanical connections and possible leaky seals. Although these occurrences are not common, using the pipe eliminates the chance altogether.

The following section outlines how to size expansion loops. The method of calculation of loop size is independent of the type of system expansion. An example is included to better understand how to use the equations and lay out a system.

To start, first determine the amount of growth in the pipe system due to the temperature change. The change in pipe length is calculated as follows:

$$\Delta L = 12 \times L \times \alpha \times \Delta T \quad (C-54)$$

Where: ΔL = change in length (in)
 L = length of the pipe run (ft)
 α = coefficient of thermal expansion (in/in/° F)
 $\alpha = 6.67 \times 10^{-5}$ for PVDF
 $\alpha = 8.33 \times 10^{-5}$ for PP
 $\alpha = 8.33 \times 10^{-5}$ for HDPE
 ΔT = temperature change (° F)

ΔT is the maximum temperature (or minimum) minus the install temperature. If the installation temperature or time of year is unknown, it is practical to increase the ΔT by 15% for safety. It is not necessary or practical to use the maximum temperature minus the minimum temperature unless it will truly be installed in one of those conditions.

After determining the amount of expansion, the size and type of the expansion/contraction device can be determined. The use of loops, offsets, or existing changes in directions can be used in any combination to accommodate for the expansion. To determine the length and width of an expansion loop, use Equation C-55.

$$A = C \sqrt{D \Delta L} \quad (C-55)$$

Where: A = loop length (in)
 C = constant
 $= 20$ for PVDF
 $= 30$ for PP, PE
 D = pipe OD (in)
 ΔL = change in length (in)

The loop width is the length A divided by 2. See Figure C-20 for an example of a typical loop.

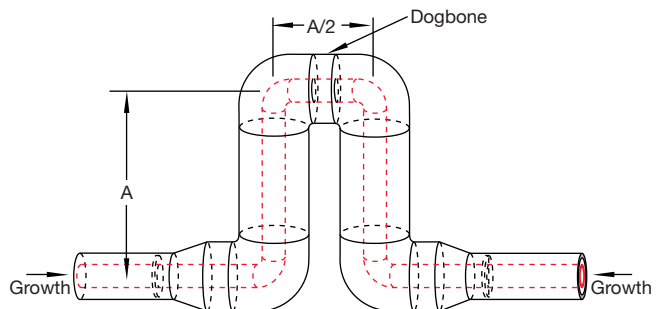

Figure C-20. Loop

An offset can be calculated in the same manner using Equation C-56. Figure C-21 depicts a typical offset to be used to accommodate for thermal expansion.

$$A = C \sqrt{2 D \Delta L} \tag{C-56}$$

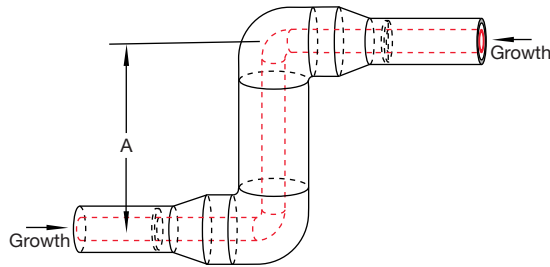

Figure C-21. Offset

The last choice is to accommodate the expansion using existing changes in direction. By allowing pipe to flex at the corners, stress can be relieved without building large expansion loops.

For a change in direction to properly relieve stress, the pipe must not be locked for a certain distance allowing the turn to flex back and forth. Use Equation C-55 and Figure C-22 to properly design changes in direction.

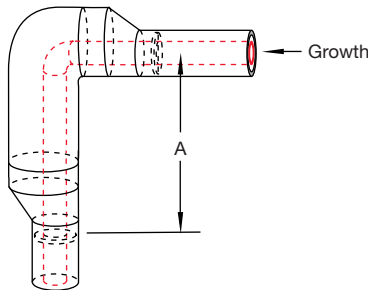

Figure C-22. Changes in direction

The distance A is the amount of distance required prior to placing an anchor on the pipe from the elbow. By leaving the distance “A” free floating, the pipe can expand and contract freely to eliminate stress on the system. Within the distance A, it is still required to support the pipe according to the standard support spacing, but without fixing it tightly. Since the pipe will be moving back and forth, it is important to ensure the support surface is smooth and free of sharp edges that could damage the pipe.

As with all three methods of expansion compensation, it is necessary to use hangers that will anchor the pipe in certain locations and allow it to be guided in other locations. Guides are extremely important to ensure that the expansion is eliminated within the compensating device and not by the pipe bowing or snaking.

Carrier Expansion, Containment Constant

Flexible Design

Using the equations and methods previously described will allow for the design on the inner loop dimensions. However, the containment pipe must be sized to allow the movement of the inner pipe. Below is an example of a short run of pipe designed to be flexible.

EXAMPLE

A 3 x 6 – 75 foot run of Pro 150 x Pro 45 polypropylene pipe is locked between existing flanges that will not provide any room for expansion. The double containment pipe is continuous and will be terminated inside the two housings. The ΔT will be 60° F. The containment pipe is buried, and the thermal expansion only affects the carrier pipe.

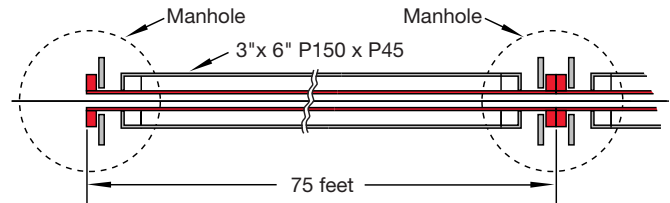

Figure C-23. Detail of system

From the proposed installation, all the thermal expansion will need to be made up in the pipe run itself. Since the pipe run is straight, the use of an expansion loop(s) is the best method.

First, determine the amount of expansion that must be compensated.

$$\Delta L = 12 \alpha L \Delta T$$

$$\Delta L = 12 \cdot (8.33 \times 10^{-5})(75)(60)$$

$$\Delta L = 4.50 \text{ inches}$$

Next, determine the size of the loop. Based on the result of the calculation, it can be determined if more than one loop will be required.

$$A = C \sqrt{D \Delta L}$$

$$A = 30 \sqrt{3.54 (4.5)}$$

$$A = 119 \text{ inches} = 10 \text{ feet}$$

For this application, it is determined that one loop is sufficient. The system will have the following layout.



EXAMPLE (continued)

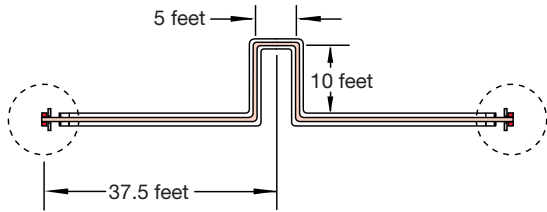

Figure C-24. Expansion layout

The last step is to determine the size of the outer wall pipe. Since the loop has been designed to compensate for a maximum growth of 4.5 inches, it is known that the carrier pipe will grow into the loop 2.25 inches from both directions. See Figure C-25 for clarification.

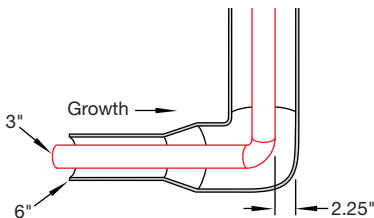

Figure C-25. Expansion into the loop

The annular space in the containment pipe must be designed to allow for the free movement of the carrier pipe, a total distance of 2.25 inches. In this particular case, based on the OD of the carrier and ID of available containment piping, the containment pipe must be increased in size to a 10" Pro 45 outer wall pipe. Figure C-26 depicts the cross-sectional view of the pipe and the new expansion loop design.

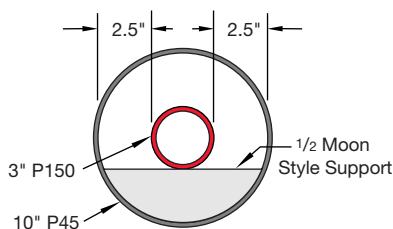

Figure C-26. Cross-sectional view

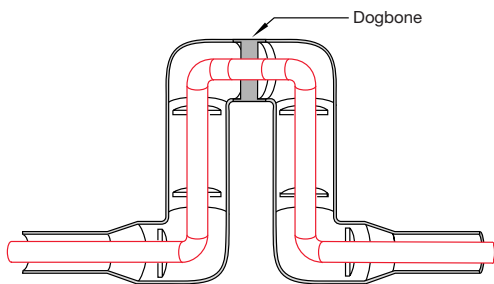

Figure C-27. New double contained expansion loop

Carrier Constant, Containment Expansion

Flexible Design

These systems are designed in the same fashion. Work with the equations as if the outer wall piping is a single wall pipe system.

The use of loops, offsets, or changes in direction is the same design method, except in this case it is important that the carrier pipe does not restrict the growth of the containment piping. The methodology to avoid this from occurring is the same as in the previous section.

Flexible System — Final Considerations

In all double wall piping systems that require a flexible design, some similar installation and design practices apply.

All flexible systems require staggered butt-fusion assembly. Since the inner and outer piping are expanding and contracting at different rates, the support disc that locks the two pipes together for simultaneous fusion cannot be used. For a flexible system, the inner weld must be conducted and then the outer weld. See Section F, *Installation Practices*, for staggered welding procedures.

As in a single wall flexible system, it is important to control and direct the direction of the expansion. In hanging systems, the use of guides and anchors is critical to properly direct the growth. In buried systems, the spider clips provided within the pipe are used to guide the carrier pipe inside the containment.

Dogbones are again used to anchor the pipe. From the location of the anchoring Dogbone, the direction of the expansion is known. These fittings are used at all points of required anchoring.

Poly-Flo Thermal Expansion Design

A Poly-Flo double containment piping system is similar to that of a single wall pipe. Poly-Flo pipe is made with continuous supports between the carrier and containment pipe. The pipe is extruded all as one piece, different than any other fabricated double containment pipe system available in the world. Since the carrier, the containment, and the ribs are all one homogenous component, the containment pipe will expand and contract at the same rate as the carrier pipe.

Asahi/America has tested the effect of expanding the inner pipe and verified that the outer pipe will expand at the same rate with minimal stress to the rib support system.

Therefore, a Poly-Flo system should be designed for thermal expansion in the same manner as a single wall piping system.

For further understanding of thermal expansion, consult with the Asahi/America, Inc. Engineering Department to review any needs of a specific project.

HANGING PRACTICES

Hanging any thermoplastic system is not that much different than hanging a metal system. Typically the spacing between hangers is shorter, due to the flexibility of plastic. In addition, the type of hanger is important.

Hanging Distances

Hangers should be placed based on the spacing requirements provided in Appendix A. Since thermoplastic materials vary in strength and rigidity, it is important to select hanging distances based on the material you are hanging. Also, operating conditions must be considered. If the pipe is operated at a higher temperature, then the amount of hangers will be increased. Finally, if the system is exposed to thermal cycling, the placement of hangers, guides, and anchors is critical. In these cases, the hanger locations should be identified by the system engineer and laid out to allow for expansion and contraction of the pipe over its life of operation.

Hanger Types

When selecting hangers for a system, it is important to avoid using a hanger that will place a pinpoint load on the pipe when tightened. For example, a U-bolt hanger is not recommended for thermoplastic piping.

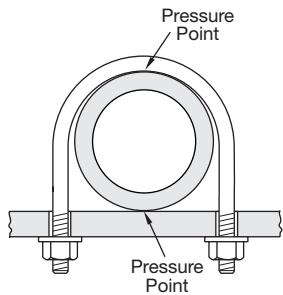

Figure C-28. Effects of U-bolt on pipe

Hangers that secure the pipe 360° around the pipe are preferred. Thermoplastic clamps are also recommended over metal clamps, as they are less likely to scratch the pipe in the event of movement. If metal clamps are specified for the project, they should be inspected for rough edges that could damage the pipe. Ideally, if a metal clamp is being used, an elastomeric material should be used in between the pipe and the clamp. This is a must for PVDF and E-CTFE systems, which are less tolerant to scratching. Figure C-28a illustrates some recommended hanger types.

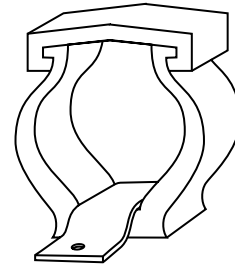
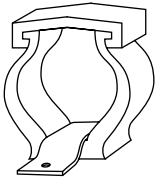

Figure C-28a. Recommended clamp

If a clamp will be used as an anchor and it will be exposed to high end loads, a more heavy duty clamp may be required, as well as a special anchoring setup. In these cases it is advised to either consult a mechanical engineer with experience in pipe stress analysis or receive detailed recommendations from the clamp manufacturer .



C



All Thermoplastic Hanger
(recommended for plastic pipe)
Available from Asahi/America

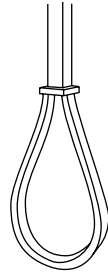

Adjustable Solid Ring
(swivel type)

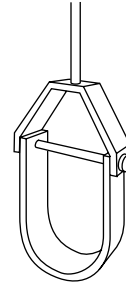

Clevis Hanger

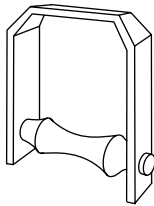

Roller Hanger

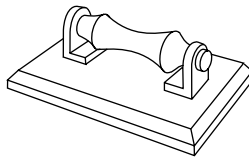

Pipe Roller and Plate

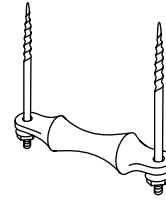

Single Pipe Roller

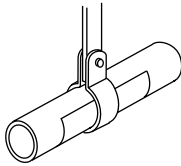

Band Hanger with
Protective Sleeve

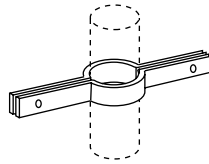

Riser Clamp



Double-Bolt Clamp

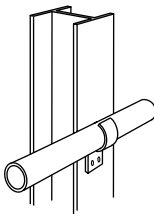

Vertical Clamp

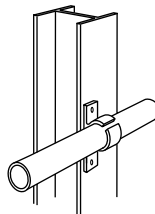

Vertical Pipe Clip

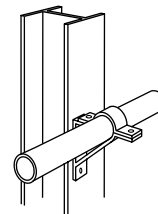

Vertical Offset Clamp

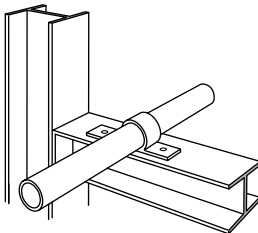

U-Type Clamp

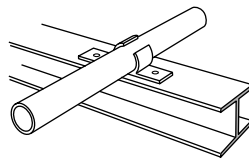

Horizontal Pipe Clip

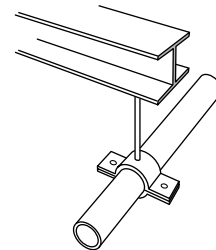

Suspended Ring Clamp

Figure C-29. Typical plastic piping restraints

BURIAL PRACTICES FOR SINGLE WALL PIPING

When designing for underground burial of thermoplastic piping, both static earth loads and live loads from traffic must be taken into account. The static load is the weight of the column of soil on the piping. The actual static load that the pipe is subjected to is dependent on many factors: the type of soil, the compaction of the soil, the width and detail of the trench, and the depth that the pipe is buried. The deeper the burial, the higher the load.

Burial of Single Wall Piping

Live loads decrease radially from the point at the surface from which they are applied. Live loads will have little effect on piping systems except at shallow depths. Polypropylene, polyethylene, and PVDF are flexible conduits. According to a basic rule of thumb, at least 2% deflection can be achieved without any structural damage or cracking. When analyzing a system for capability of withstanding earth and live loading, deflection under proposed conditions are compared to maximum allowable deflection (5% for PP and PE and 3% for PVDF) and the adequacy is thus judged.

Determination of Earth Loads

The method for determining earth loads of a flexible conduit is the Marston Theory of loads on underground conduits. From the theory, it is concluded that the load on a rigid conduit is greater than on a flexible conduit. To determine the earth load on a flexible conduit, the Marston equation for earth loads is used. The ratio of the load on a rigid conduit to the load on a flexible conduit is:

$$\frac{W_c \text{ (rigid)}}{W_c \text{ (flexible)}} = \frac{B_d}{B_c} \tag{C-57}$$

$$W_c = C_d w B_d B_c \tag{C-58}$$

- Where: W_c = load on conduit, (lbs/linear ft)
- w = soil density, (lbs/ft³)
- B_c = horizontal width of conduit (ft)
- B_d = horizontal width at top of trench (ft)
- C_d = load coefficient

Therefore, the theory implies that a trench width twice the width of a conduit being buried will result in a load on a rigid conduit twice that of a flexible conduit. Figure C-30 displays the dimensions indicated in Equation C-57.

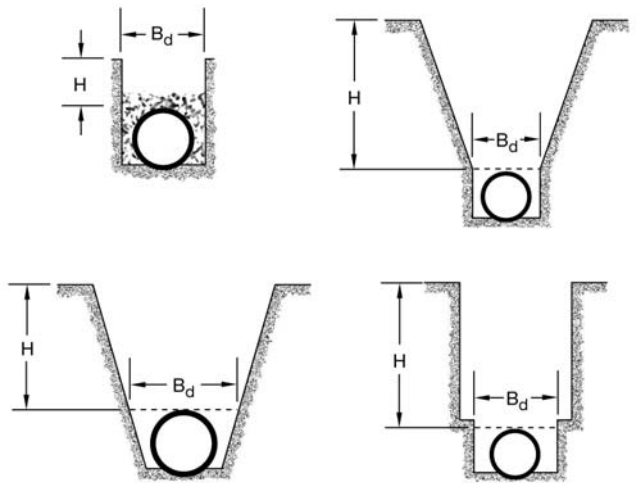

Figure C-30. Example of underground installation

The load coefficient, C_d , depends on the ratio of the height of the fill to the trench width and can be determined from the following equation.

$$C_d = \frac{(1 - e^{-(2K\mu H/B_d)})}{2K\mu} \tag{C-59}$$

- Where: e = natural logarithm base
- K = Rankine's ratio of lateral to vertical pressure
- μ = coefficient for friction between backfill material and sides of the trench

From Equation C-59, a larger load can be expected at increasing widths. As trench width increases, this load increases at a decreasing rate until a value as prism load is attained. For most applications, this value can be calculated as follows:

$$W_c = H w B_c \tag{C-60}$$

And prism load, expressed in terms of soil pressure, is as follows:

$$P = W_c H$$

- Where: P = pressure due to soil weight at depth H (lbs/ft²)
- H = height of fill (ft)

Prism loading is the maximum attainable load in a burial situation and represents a conservative design approach. Due to the fact that frost and water action in a soil may dissipate frictional forces of the trench, the long-term load may approach the prism load. Therefore, it is recommended that this load be considered when designing an underground thermoplastic piping system.



Simplified Method for Burial Design

To properly determine the feasibility of thermoplastic piping system in a buried application, follow the steps below. These steps will provide the proper design to resist static soil loads.

Step 1.

Determine the soil load exerted on the pipe in lbs/linear foot.

The following information is required:

Pipe Diameter: _____

Soil Type: _____

Trench Width: _____

Burial Depth: _____

With this data, use the Martson Soil Load Tables found in Appendix B to determine the actual load on the pipe. It is critical to pay particular attention to the trenching details. If proper trenching cannot be accomplished, values for the load should be determined using the prism load values, also found in Appendix B.

Actual Soil Load: _____ per linear foot

Step 2.

Determine the E' Modulus of the soil.

E' Modulus values are based on the soil type and the proctor (see Appendix B for table). If on-site conditions are not known, use a low value to be conservative.

E' = _____

Step 3.

Determine the allowable load on the pipe.

The allowable load on the pipe is compared to the actual load to determine suitability of the burial application. In addition, safety factors can be calculated. Allowable loads are based on the pipe diameter, material, wall thickness, and E' Modulus. To determine the allowable loads, use the tables in Appendix A for Polypropylene, PVDF, and HDPE. Be sure to use the tables by wall thickness and material.

Max allowable soil load _____ per linear foot

If the actual load is less than the allowable load, the installation is acceptable, providing a 2:1 safety factor is present.

Safety Factor = Max allowable load/ actual soil load.

SF = _____

If the maximum allowable is less than the actual load, changes will have to be made, such as burial depth, trench details, or pipe wall thickness. The allowable loads for Duo-Pro pipe are based on an allowable ring deflection of 5% for PP and HDPE and 3% for PVDF.

Live Load Designs

For applications where live loads are present, a general rule of thumb is to place the pipe 5 feet below the source of the live load. If piping is only being exposed to a live load in a short length, and cannot be placed 5 feet down, it may be advantageous to sleeve the pipe through a steel pipe or enclose it in concrete.

In general, live loads should be added to static earth loads to determine the total load exerted on the pipe under site conditions. In Figure C-31, H20 highway loading, the effects of live load and static earth loads combined on a pipe can be viewed. In shallow depths, shallower than the 5-foot mark, the effect of traffic is significant and needs to be added to the static load to determine the effect. From the graph, it is demonstrated that at deeper depths the effect of a live load becomes a minimal effect. In all cases of static and live loads, consult Asahi/America's Engineering Department for assistance on design.

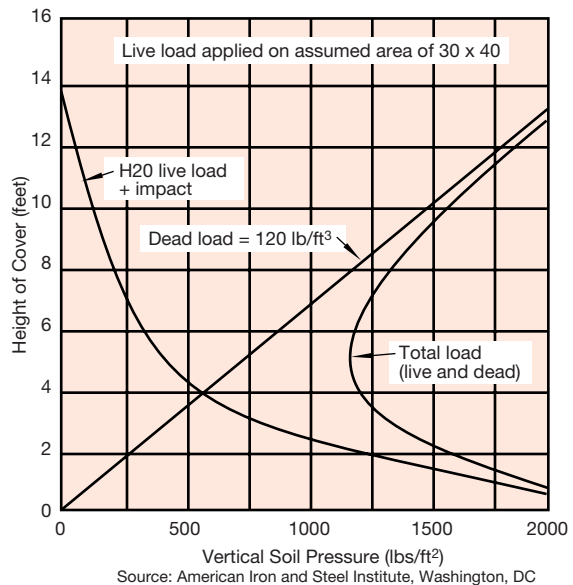

Figure C-31. H20 highway loading

BURIAL PRACTICES FOR DOUBLE WALL PIPING

The procedure is the same as that of a single wall system. All calculations should be based on the outer wall, containment, pipe OD, and wall thickness.

If leak detection cable is used on a buried double wall system, it is necessary to calculate the actual deflection and the resulting annular space to ensure the cable will have adequate clearance. See Figure C-32.

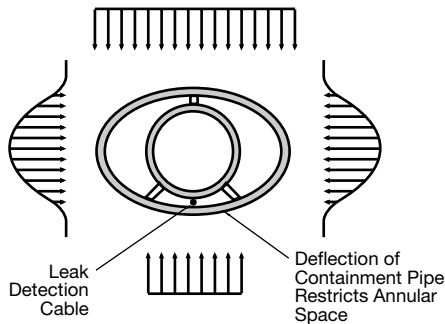

Figure C-32. Deflection of double contained pipe

The following formula is used to calculate deflection on the containment pipe.

$$\Delta X = D_L \frac{(K W_c r^3)}{(E I + 0.061 E' r^3)} \tag{C-61}$$

- Where: ΔX = horizontal deflection based on inside diameter (in)
- D_L = deflection lag factor (use 1.5)
- K = bedding constant (Appendix B)
- W_c = Marston load per unit length of pipe (lbs/linear in)
- r = radius of pipe (in)
- E = modulus of elasticity of pipe materials (psi)
- I = moment of inertia of the pipe wall (in³) = $t^3/12$ (App A, Table A-28 to A-32)
- E' = modulus of soil reaction (psi)

INSTALLATION OF A BURIED SYSTEM

These preparations can be used for either single wall or double contained piping systems.

Trench Preparation—General

The recommended trench width for both single wall and double can be found by adding one foot to the width of the pipe to be buried. Larger trench widths can be tolerated, but trench widths greater than the diameter plus two feet typically produce large loads on the pipe. For small diameter pipes (4" and less), smaller trench widths are suggested. The important point to remember is the trench width at the top of the conduit is the dimension that determines the load on the pipe. Therefore, the sides of the trench can be sloped at an angle starting above this point to assist in minimizing soil loads in loose soil conditions (prior to compaction). If the trench widths described are exceeded, or if the pipe is installed in a compacted embankment, it is recommended that embedment should be compacted to 2.5" pipe diameters from the pipe on both sides. If this distance is less than the distance to the trench walls, then the embedment materials should be compacted all the way to the trench wall.

When installing long lengths of piping underground, it may not be necessary to use elbows, as long as the minimum radius of bending for specific diameters and wall thicknesses are observed. If the soil is well compacted, thrust blocks are not required. However, if changes of directions are provided with tees or elbows, or if the soil is not well compacted, thrust blocks should be provided. The size and type of a thrust block is related to maximum system pressure, size of pipe, direction of change (vertical or horizontal), soil type, and type of fitting or bend. To determine thrust block area, it is suggested that a geotechnical engineer be consulted, and soil bearing tests be conducted if deemed necessary.

If the bottom of the trench is below the water table, actions must be taken to adequately correct the situation. The use of well points or under-drains is suggested in this instance, at least until the pipe has been installed and backfilling has proceeded to the point at which flotation can no longer occur. The water in the trench should be pumped out, and the bottom of the trench stabilized with the use of suitable foundation material, compacted to the density of the bedding material. In a double containment system, annular spaces must be sealed to prevent water from getting into the space.

For unstable trench bottoms, as in muddy or sandy soils, excavate to a depth 4 to 6 inches below trench bottom grade, backfill with a suitable foundation material, and compact to the density of the bedding material. Be sure to remove all rocks, boulders, or ledge within 6 inches in any direction from the pipe. At anchors, valves, flanges, etc., independent support should be provided by the use of a reinforcing concrete pad poured underneath the pipe equivalent to five times the length of the anchors, valves, or flanges. In addition, reinforcing rods should be provided to securely keep the appurtenance from

shifting, thereby preventing shearing and bending stresses on the piping. It is strongly suggested that an elastomeric material be used to prevent stress concentration loading on the piping caused by the reinforcing rod.

Laying of Pipe Line and Backfilling Procedure

Caution must be exercised so that the laying of straight lengths or piping prepared above ground do not exceed the minimum bending radius of the piping. For a given trench height, "h", the minimum length of piping necessary to overcome failure due to bending strain can be determined by the following procedure.

Step 1.

Determine trench height = "h". This trench height will equate to the offset value "A".

$$A = 2R_b (\sin Q)^2 \quad (C-62)$$

Step 2.

Determine R_b from longitudinal bending tables (see Appendix A) for the pipe diameter to be laid.

Step 3.

Determine the angle of lateral deflection (α).

$$\alpha = \sin^{-1} \left(\frac{h}{2R_b} \right)^{1/2} \quad (C-63)$$

Step 4.

Determine the central angle β .

Step 5.

Determine the minimum length "L" in inches.

$$L = \frac{\beta R_b}{57.3} \quad (C-64)$$

Where: h = A = height of trench (in)
 β = 2α = central angle (degrees)
 R_b = radius of bending (in)
 (Appendix A)
 L = minimum laying length (in)

If the value determined in Step 5 is greater than the entire length to be buried, due to a deep trench or short segment, then the entire length should be lifted with continuous support and simultaneously placed into the trench.

If the pipe is pulled along the ground surface, be sure to clear the area of any sharp objects. Some means to prevent scarring to minimize soil friction should be used. Since the allowable

working stress at pipe laying surface temperature should not be exceeded, pulling force should not exceed:

$$PF = SF \times S \times A \quad (C-65)$$

Where: PF = maximum pulling force (lbs)
 S = maximum allowable stress (psi)
 A = cross-sectional area of pipe wall (in²)
 SF = safety factor = 0.5

Since the soil will provide friction against a pipe that is being pulled on the ground, a length "L" will be achieved where the pipe can no longer be pulled without exceeding maximum allowable stress of the piping. This length can be estimated by:

$$L = \frac{2.3 SF S}{(\mu \cos \phi + \sin \phi)} \quad (C-66)$$

Where: L = maximum pulling length (feet)
 S = maximum allowable stress (psi)
 SF = safety factor = 0.5
 μ = coefficient of friction between the soil and pipe wall
 ϕ = gradient (ground slope)

Muddy soil with a low coefficient of friction will allow for a longer length to be pulled.

For small diameter pipes (2 1/2" and under), the pipe should be snaked, particularly if installed during the middle of a hot summer day. The recommendations for offset distance and snaking length should be observed, as outlined in this section, *Thermal Expansion*. It is suggested that the laying of the pipe into the trench on a summer day take place first thing in the morning to minimize thermal contraction effects. For larger diameter pipes with well compacted soil, friction should prevent pipe movement due to thermal expansion and minimize the need for snaking, although it is still recommended.

The initial backfilling procedure should consist of filling in on the sides of the piping with soil free of rocks and debris. The filling should be compacted by hand with a tamping device, ensuring that the soil is forced under the pipe, and should continue until a level of compacted fill 6" to 12" above the top of the pipe is achieved. This process should be performed in gradual, consistent steps of approximately a 4" layer of fill at any one time to avoid the arching effect of the soil. When this procedure is accomplished, the final backfill can proceed. With a soil that is free of large rocks or other solids, the final fill can be accomplished.

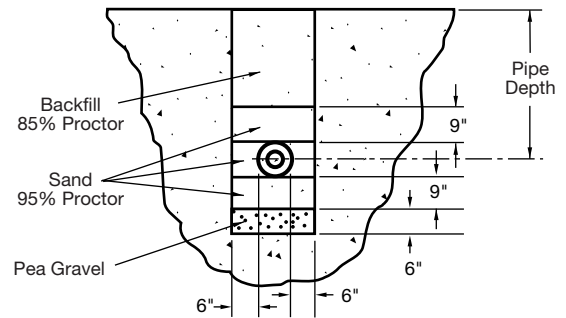

Figure C-33. Example of underground installation

The piping location should be accurately recorded at this point, and it may be a wise idea to place a conductive wire or shield in the vicinity in order to locate the piping at a later date by the use of an underground metal detector. This will ensure that piping can still be located if the installation plans are misplaced.

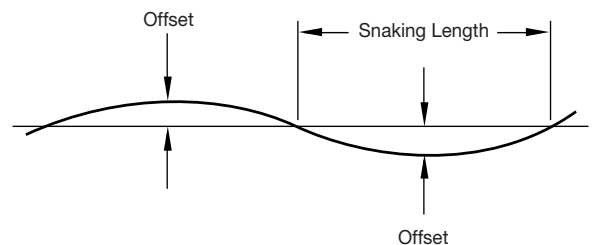

Figure C-34. Illustration of terms relating to snaking of pipe within a trench

PIPE BENDING

As previously mentioned, many thermoplastic piping systems can be bent to reduce the usage of fittings. Pipe bending procedures are dependent on the intended radius, the material, and size and wall thickness of the pipe. Consult with Asahi/America for procedural recommendations.

C To determine the minimum allowable radius, see Appendix A. Tables App. A-15 and App. A-16 provide factors for bending based on material and size. Polypropylene and HDPE can be bent in the field, but bending PVDF is not recommended.

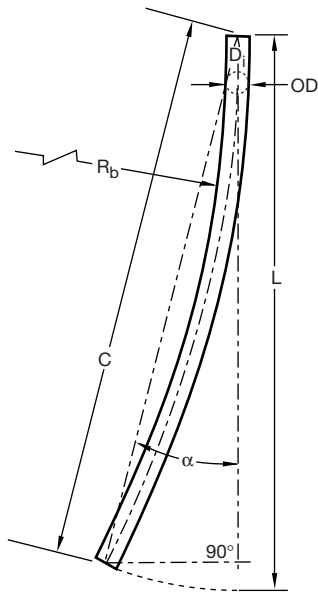

Figure C-35. Asahi/America pipe allowable bend

HEAT TRACING AND INSULATION

Heat tracing of thermoplastic pipes differs considerably than that of metals. Some of the important contrasts include: poor thermal conductivity of the pipe material, upper-temperature limitations of the pipe material due to low melting ranges and combustibility features, high expansion and contraction characteristics and the resulting insulation restrictions, poor grounding qualities for electrical currents, and the typical harsh environmental consideration to which plastic piping is frequently exposed to. External steam tracing is strongly not recommended, due to the upper temperature limitations. However, there are two very reliable methods of providing freeze protection and/or temperature maintenance: external electrical heat tracing using “self-regulating” style electrical heaters, and the internal method of using a smaller diameter pipe that conveys a hot fluid to transfer heat to the fluid flowing in the annular space. Both methods require a slightly different design method, and also require their own unique fabrication techniques. When designing a system using either of these methods, it is suggested that the factory be contacted for technical advice pertaining to the particular situation. Manufacturers of heat tracing also now offer computer programs to determine the proper system for an application. Raychem offers the TraceCalc program for such applications.

Thermal Design

The heat loss calculations to determine the amount of heat that must be replaced by the heater are based on the Institute of Electrical and Electronics Engineers (IEEE) Standard 515-1983, Equation 1, with the following modification. Since the factor for pipe wall resistance cannot be neglected for plastics, a term for pipe wall resistance is also included. Pipe heat losses are shown at a variety of temperature differences and insulation thicknesses. Heat loss for Asahi/America piping can be found in Appendix A. The information is based on foamed elastomer insulation, according to ASTM C-534, located outdoors in a 20 mph wind, no-insulating air space assumed between insulation and outer cladding, and negligible resistance of the outer cladding; thereby, providing an additional margin of safety in the calculations. To determine heat loss through the insulated pipe, the following procedure should be used.

Step 1.

Determine applicable conditions such as type of piping, internal fluid, minimum expected temperature condition, desired maintenance temperature, outdoor or indoor condition (applicable wind velocity for outdoor condition), amount and type of insulation desired, etc.

Step 2.

Determine ΔT by subtracting the minimum expected design temperature from the desired maintenance temperature.

Step 3.

Determine Q (heat loss) in watts per linear foot by using Equation C-67 or by using the heat loss tables found in Appendix A.

$$Q = \frac{\pi L \Delta T}{\frac{1}{h_i D_i} + \frac{\ln(D_o/D_i)}{2k_p} + \frac{1}{h_o D_o} + \frac{\ln(D_{ins}/D_o)}{2k_{ins}} + \frac{1}{h_{ins} D_{ins}} + \frac{1}{h_{wb} D_{wb}}}$$

(C-67)

- Where: K_p = thermal conductivity of the pipe (BTU.in/ft² h ° F)
- K_{ins} = thermal conductivity of the insulation (BTU.in/ft² h ° F)
- D_i = inside pipe dimension (in)
- h_o = inside air contact coefficient, pipe to insulation (BTU.in/ft² h ° F)
- D_o = pipe outside diameter (in)
- D_{ins} = combined outside diameter of the pipe plus insulation (in)
- h_{ins} = inside air contact coefficient, insulation to weather barrier (BTU.in/ft² h ° F)
- D_{wb} = combined outside diameter of the pipe, insulation, and weather barrier (in)
- h_{wb} = heat transfer coefficient of the outside air film (BTU.in/ft² h ° F)
- H_i = heat transfer coefficient of the inside air film (BTU.in/ft² h ° F)

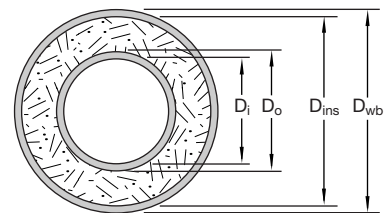

Figure C-36. Double containment pipe

Step 4.

If the desired type of insulation is not foamed elastomer, do not adjust the number found in the table by applying a design factor. Instead, Equation C-67 should be used to determine the heat loss. The resistance of the plastic pipe prevents the use of these quick insulation factors, unlike the situation experienced for metal piping where there is no pipe resistance to heat transfer.

Step 5.

For piping located indoors, multiply the values for Q (heat loss) found in the heat loss tables in Appendix A, by 0.9 to determine the corrected values.

External Self-Regulating Electrical Heat Tracing Design

Plastic piping melts at comparatively low temperatures with respect to that of metallic piping. If high enough temperatures are achieved, the external walls of a plastic pipe may become charred or burned causing damage to the external walls. Due to these features, the only recommended type of electrical heat tracer is the self-regulating type. A product with high reliability that is compatible with thermoplastic piping systems is Chemelex® Auto-Trace® heaters, manufactured by Raychem Corporation of Menlo Park, CA. By automatically varying heat output, Auto-Trace heaters compensate for installation and operating variables such as voltage fluctuations, installation, heat sinks, and ambient temperature changes, while continuing to provide necessary heat for system operation.

Self-regulation works by the use of a unique heating element that is a specially blended combination of polymer and conductive carbon, creating electrical paths between the parallel bus wires at every point along the circuit. As it warms, the core expands microscopically, increasing resistance to electrical flow and causing the heater to reduce its power output. As the surrounding temperature cools the core, it contracts microscopically, decreasing resistance and increasing the heater output. In addition, the heat distribution along the pipe surface can be more evenly controlled as the heater will vary its power output in accordance with the state of the heater core. In cold spots, the core contracts microscopically creating many electrical paths through the conductive carbon. The flow of electricity through the core generates heat. In warmer sections, the core expands microscopically, disrupting many electrical paths. The increased electrical resistance causes the heater to reduce its power output. In hot sections, the microscopic core expansion disrupts almost all the electrical paths. With this high resistance to electrical flow, power output is virtually zero. Thus the heat distribution is very even, and hot spots along the temperature sensitive plastic pipe and insulation are avoided.

Other features of self-regulating heaters include parallel circuitry for cut-to-length convenience at the job site, flexibility for easy field installation, and circuit length up to 1,000 feet (305 meters). In addition, reduced operating cost is achieved by balancing heat loss through efficient energy use, compensation for local temperature variation, and minimal maintenance due to long lasting reliability. Engineering design assistance is provided through Asahi/America's Engineering Department on request.

To design a system with electrical heat tracing, the following variables must be known: design temperature difference (ΔT) found as shown in the thermal design section of this chapter in watts per linear foot of pipe, voltage, area classification, chemical environment, type and number of valves, flanges and supports, and total pipe length. Once these factors are known, the following procedure is used to design the electrical heat tracing for the piping system.

Step 1.

Select the appropriate family of heater based upon the maximum exposure temperature and the desired maintenance temperature.

Step 2.

Select an appropriate heater from the thermal output curves for that particular heater, so that the thermal output at the maintenance temperature equals or exceeds the heat loss. Since polypropylene, HDPE, and PVDF have much lower thermal conductivities than that of metals, the power output curves should be adjusted. It is suggested that a power output adjustment factor of between 0.5 to 0.75 be used to derate the stated power outputs at the design temperature of the pipe. This factor takes into account that ΔT -180 aluminum tape be used over the heater. It is suggested the tape be used both over and under the heater to aid in heat transfer. Without any tape at all, a factor between 0.3 and 0.5 should be applied to the power to derate the stated power outputs.

Step 3.

Should the heat loss already calculated be greater than the power output of the selected heater:

- Use thicker insulation
- Use insulation with a lower thermal conductivity
- Use two or more parallel strips
- Spiral the heat tracing or
- Use product from the same family with higher thermal output rating

Step 4.

When spiralling of the heater is chosen as in Step 3 above because more than one foot of heater is required per foot of pipe, divide the pipe heat loss per foot by the heat output of the selected heater (at the desired maintenance temperature) to calculate the spiral factor. Use Table C-4 to determine the pitch. Refer to Figure C-44 for an illustration on how to measure pitch.

Step 5.

Determine the total length of the heater required by combining lengths from each component in the piping system. For the piping, calculate the amount of heater required for the pipe length. In the case of a straight heater run, this quantity is equal to the total length of piping.

For each pair of bolted flanges, add a heater length equal to two times the pipe diameter.

For each valve, add a heater length determined by multiplying the heat loss Q by the valve factor provided in Table C-5 and dividing by the heater output at the maintenance temperature.

$$L_h = \frac{Q F_v}{T_m} \quad (C-68)$$

- Where: L_h = length of heater (ft)
 Q = pipe and insulation loss (watts/linear foot • hour)
 F_v = valve factor (see Table C-5)
 T_m = maintenance temperature (°F)

For each pipe hanger, add a heater length equal to three times the pipe diameter.

Step 6.

In hazardous or classified areas, or in applications where a ground path must be provided, or in general harsh environments, select the optional heater coverings as follows:

For dry and non-corrosive environments where a ground path is required, use the tinned copper shield covering.

For limited exposure to aqueous inorganic chemicals, use the tinned copper shield with modified polyolefin outer jacket. (For BTV™ type heater only.)

For limited exposure to organic or inorganic chemicals, use the tinned copper shield with the fluoropolymer outer jacket.

Step 7.

Select the heater voltage from either the 120 Vac or 240 Vac options. If the 240 Vac option is selected, but the available voltage differs from the product rating, the heater output must be adjusted by using appropriate factors. Consult the maker of the heat tracing for the appropriate factors.

Table C-4. Spiral Factor/Pitch

Pipe Size (ips)	Spiral Factor (feet of auto-tractor per feet of pipe)				
	1.1	1.2	1.3	1.4	1.5
1.0	NR	NR	NR	NR	NR
1.5	NR	NR	NR	NR	NR
2.0	17	NR	NR	NR	NR
2.5	20	14	NR	NR	NR
3.0	24	17	13	NR	NR
3.5	28	19	15	13	NR
4.0	31	21	17	14	NR
4.5	35	24	19	16	14
5.0	39	26	21	18	15
6.0	46	31	25	21	18
8.0	59	41	33	28	24

Note: 1 inch = 2.54 cm

Insulation

Insulation is a good method of protecting a pipe system from UV exposure, as well as providing required insulation for the system or media being transported. A serious difference between plastic and metal is plastic's thermal properties. A metal pipe system will quickly take the temperature of the media being transported. A system carrying a media at 150° F will have an outer wall temperature close to or at 150° F. In contrast, thermoplastics have an inherent insulating property that maintains heat inside the pipe better than a metal system. The advantage is that a plastic pipe has better thermal properties, which translates into improved operating efficiencies and reduced insulation thickness. In a double contained plastic piping system, you have the benefit of the inherent insulation properties of the plastic plus the additional benefit of the air in the annular space between the carrier and containment pipes.



Table C-5. Valve Heat Loss Factor

Valve Type	Heat Loss Factor
Gate	4.3
Butterfly	2.3
Ball	2.6
Globe	3.9

For Example: Heat loss for a 2" gate valve is 4.3 times the heat loss for one foot of pipe of the same size and insulation.

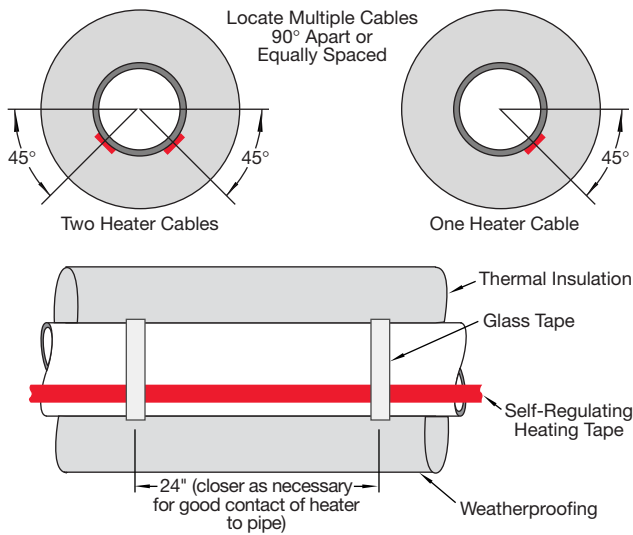

Figure C-37. Positioning of heating tape on pipe

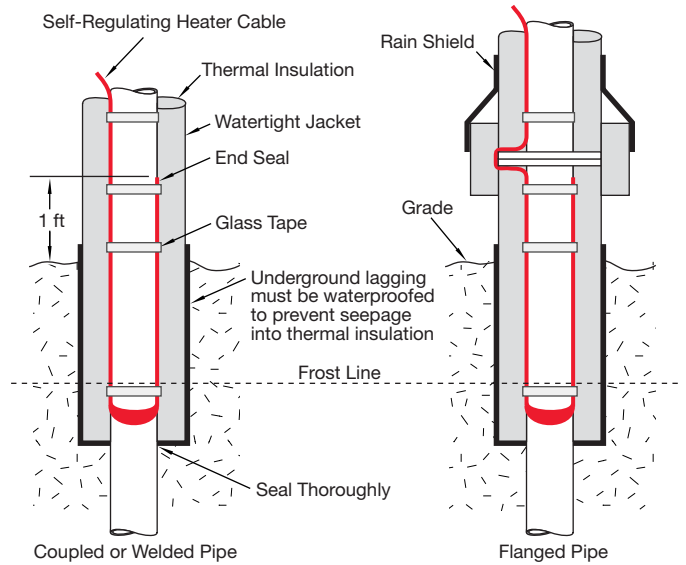

Figure C-40. Applying heating tape below grade

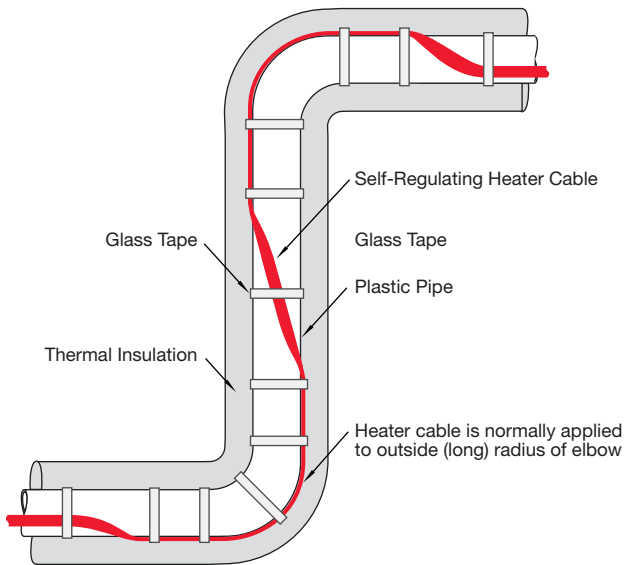

Figure C-38. Positioning of heating tape on elbows

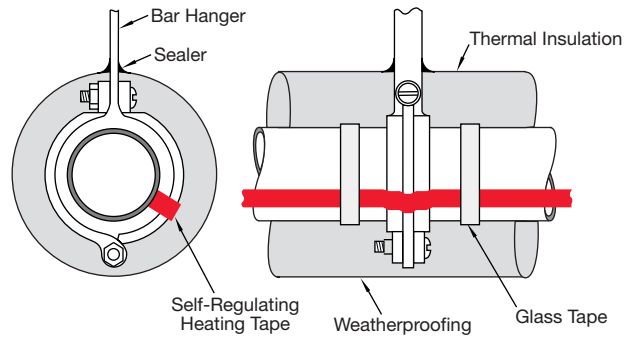

Figure C-41. Positioning of heating tape around bar hanger

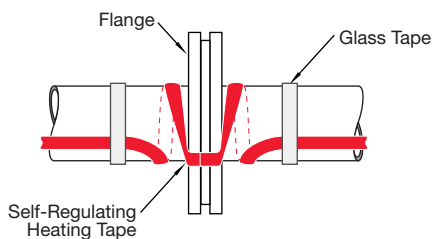

Figure C-39. Positioning of heating tape around flanges

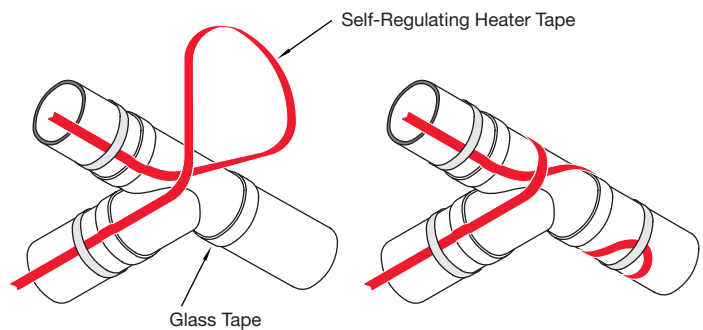

Figure C-42. Heating tape placed on tees

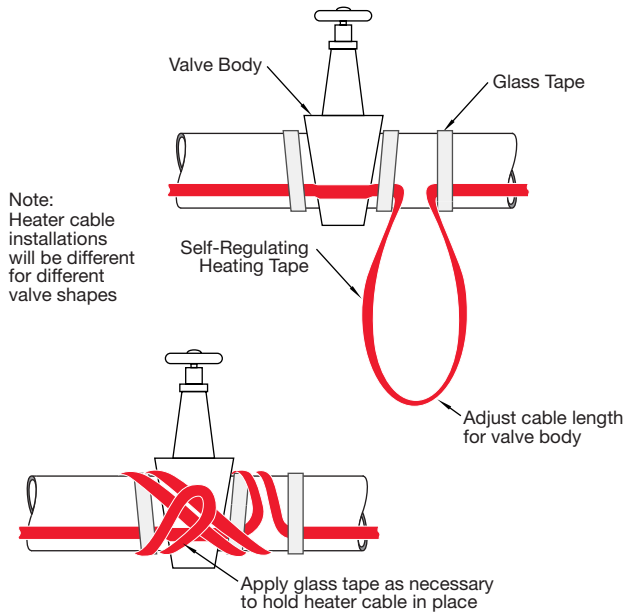

Figure C-43. Heating tape placed around valves

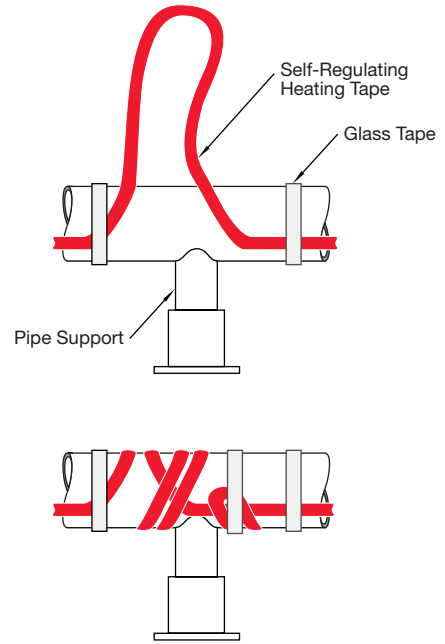

Figure C-45. Positioning of heating tape on pipe supports

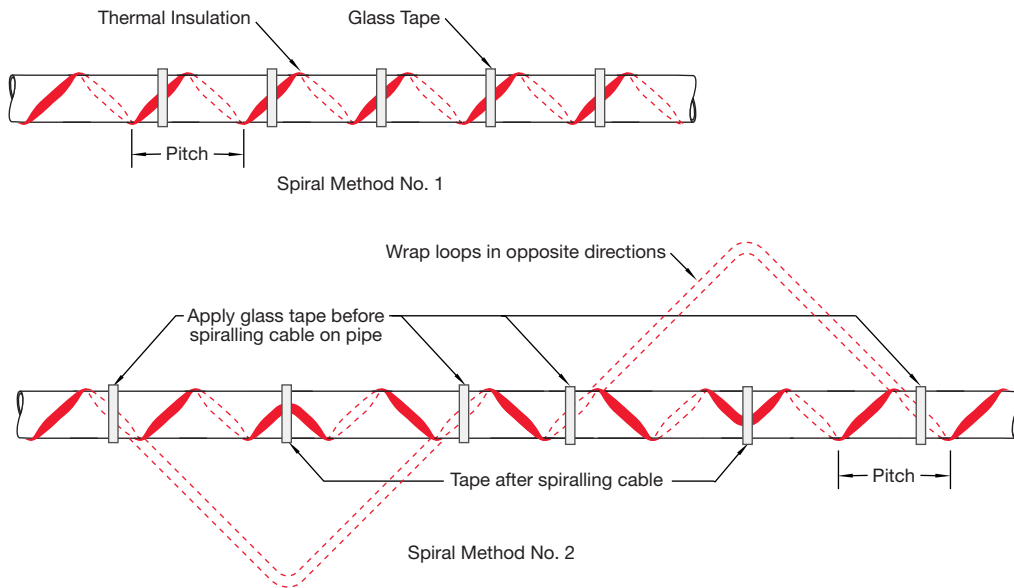

Figure C-44. Spiral wrapping of heating tape around pipes

C