

Westlock Top-Mounted Switch Box



A limit switch box is mounted on and coupled to the actuator in order to operate position-indicating lights on control panels, to control other equipment such as pumps, compressors and mixers, to sequence other valves, or for feedback and PLC position confirmation. Two single pole, double throw (SPDT) switches are mounted in one enclosure and are activated by individual, adjustable cams.

The cams are connected to the cam shaft, which is directly coupled to the actuator shaft. Switches can be set to be activated in fully open or closed positions, or in any position in the quadrant of the actuator's operation.

The limit switch box is available in NEMA Type 4X and Type 7 enclosures, and switches can be supplied in mechanical or proximity models.

The electrical rating of the standard mechanical switches is 15 amps at 250 VAC, which qualifies them for the following voltages: 12 and 24 VDC, 12, 24 and 115 VAC.

Standard Features

- Type 4X engineered resin enclosure
- UL 94H-B flammability rating
- NAMUR shaft
- CSA approved
- Beacon position indication
- Touch set cams
- Stainless steel trim
- Two 1/2" FNPT conduit entries
- Two single pole, double throw (two SPDT) limit switches; 15 amp rated

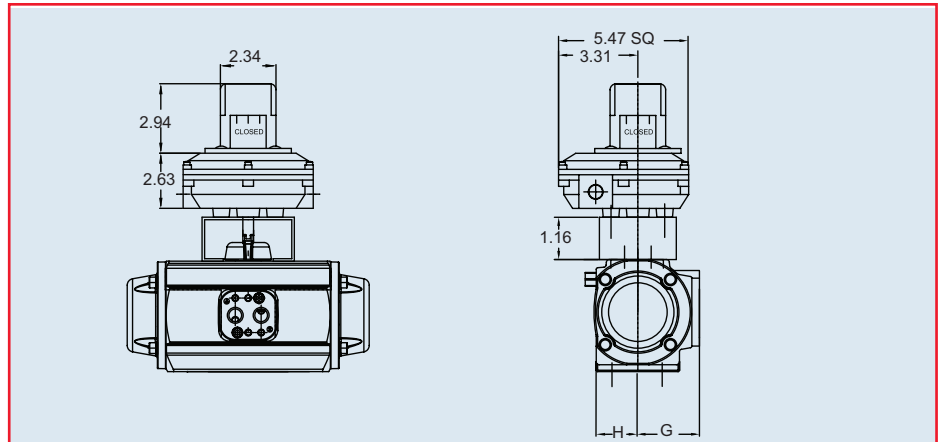

Options

- Two double pole, double throw (two DPDT) limit switches
- 4-20 mA transmitter
- NEMA 7 powder coated aluminum enclosure
- UL, CSA and FM approved Type 7