

Serial No.	H-V074-E-3
------------	------------

# Butterfly Valve Type 58

## Side Gear Type

700mm (28")~900mm(36")

### User's Manual





### Contents



1. Be sure to read the following warranty clauses of our product .....	1
2. General operating instructions .....	2
3. General instructions for transportation, unpacking and storage .....	3
4. Name of parts .....	4
5. Maximum allowable pressure and temperature .....	4
6. Installation procedure .....	5
7. Support setting procedure .....	8
8. Operating procedure .....	9
9. Liquid flow and gearbox stopper adjustment procedure .....	10
10. Inspection items .....	11
11. Troubleshooting .....	12
12. Handling of residual and waste materials .....	13

This user's guide contains information important to the proper installation, maintenance and safe use of an ASAHl AV Product. Please store this manual in an easily accessible location.

<Warning & Caution Signs>

 <b>Warning</b>	This symbol reminds the user to take caution due to the potential for serious injury or death.
 <b>Caution</b>	This symbol reminds the user to take caution due to the potential for damage to the valve if used in such a manner.

<Prohibited & Mandatory Action Signs>

	Prohibited: When operating the valve, this symbol indicates an action that should not be taken.
	Mandatory action: When operating the valve, this symbol indicates mandatory actions that must be adhered to.

## 1. Be sure to read the following warranty clauses of our product

- Always observe the specifications of and the precautions and instructions on using our product.
- We always strive to improve product quality and reliability, but cannot guarantee perfection. Therefore, should you intend to use this product with any equipment or machinery that may pose the risk of serious or even fatal injury, or property damage, ensure an appropriate safety design or take other measures with sufficient consideration given to possible problems. We shall assume no responsibility for any inconvenience stemming from any action on your part without our written consent in the form of specifications or other documented approval.
- The related technical documents, operation manuals, and other documentation prescribe precautions on selecting, constructing, installing, operating, maintaining, and servicing our products. For details, consult with our nearest distributor or agent.
- Our product warranty extends for one and a half years after the product is shipped from our factory or one year after the product is installed, whichever comes first. Any product abnormality that occurs during the warranty period or which is reported to us will be investigated immediately to identify its cause. Should our product be deemed defective, we shall assume the responsibility to repair or replace it free of charge.
- Any repair or replacement needed after the warranty period ends shall be charged to the customer.
- The warranty does not cover the following cases:
  - (1) Using our product under any condition not covered by our defined scope of warranty.
  - (2) Failure to observe our defined precautions<sup>\*1)</sup> or instructions regarding the construction, installation, handling, maintenance, or servicing of our product.
  - (3) Any inconvenience caused by any product other than ours.
  - (4) Remodeling or otherwise modifying our product by anyone other than us.
  - (5) Using any part of our product for anything other than the intended use of the product.
  - (6) Any abnormality that occurs due to a natural disaster, accident, or other incident not stemming from something inside our product.
- <sup>\*1)</sup> Note that damage induced by a defect of our product is not covered by warranty.
- This guarantee applies to the use of our product only in Japan. If it is used overseas, please inquire with us separately.

## 2. General operating instructions

### Warning



- Do not disassemble or remodel the valve and gearbox. (You may be injured.)



- Using a positive-pressure gas with our plastic piping may pose a dangerous condition due to the repellent force particular to compressible fluids even when the gas is under similar pressures used for liquids. Therefore, be sure to take the necessary safety precautions such as covering the piping with protective material. If you have any questions, please contact with our nearest sales office or distributor. For conducting a leak test on newly installed piping, be sure to check for leaks under water pressure. If absolutely necessary to use a gas in testing, please consult with our nearest sales office or distributor.

### Caution



- Do not step on or apply excessive weight on valve. (It may be damage.)  
 - Do not install the valve near excessive heat or fire. (It may be deformed, damaged and burnt.)  
 - Do not give a large vibration to the valve. (It may be failure or damage.)



- Please read and understand the User's Manual carefully before installing, operating, adjusting or inspecting the product.  
 - Always operate the valve within the pressure vs. temperature range. (The maximum allowable pressure is the pressure including water hammer pressure. The valve can be damaged or deformed by operating beyond the allowable range.)  
 - Be careful of the environment where the valve is installed. In particular, avoid places exposed to salty wind, corrosive gas, chemical solution, sea water, steam, etc.  
 - Allow sufficient space for maintenance and inspection.  
 - Select and use the appropriate material. For chemical resistance information, refer to "CHEMICAL RESISTANCE ON ASAHI AV VALVE". (Some chemicals may damage incompatible valve materials.)  
 - Use fluids containing crystalline substances under conditions that will not cause recrystallization. (The valve will not operate normally.)  
 - Keep the valve out of direct sunlight, water and dust, corrosive gas, and bad atmosphere or use cover to shield the valve. (It may be not operate properly.)  
 - Provide proper support when installing the valve. (Excessive force is applied to the valve and piping, which may cause damage)  
 - Perform periodic maintenance. (Leakage may develop due to temperature changes or over periods of prolonged storage, rest or operation.)  
 - When installing the valve, provide an appropriate support. (Failure to do so may cause breakage due to excessive force applied to the valve body and pipes.)  
 - Use the product within the specified product specifications.  
 - When used in hot liquids, misalignment of the valve and flange can damage the seat.  
 - Use flat faced flanges for connection. If it is unavoidable to use a flange other than the flat flanges (flange adapter, backing flange, etc.), the flange corner may bite into the seat depending on the valve size, and the seat may be damaged. In this case, please consult with our nearest sales office or distributor.

### 3. General instructions for transportation, unpacking and storage

#### Warning



- When suspending and supporting a valve, take care and do not stand under a suspended valve.

#### Caution



- Do not throwing or dropping the valve. (This valve is not designed to handle impacts of any kind.)
- Avoid scratching the valve with any sharp object.
- Do not contact with any coal tar, creosote, insecticides, vermicides or paint. (These chemicals may cause damage to the valve.)
- When transporting a valve, do not carry it by the hand wheel.



- Avoid exposing products to direct sunlight, and store them indoors (at room temperature). Also, avoid storing products in areas with excessive temperatures.
- After unpacking the products, check that they are defect-free and meet the specifications.
- Once you have taken the product out of its packaging or crate, clean the inside of the valve with a clean piece of waste cloth.

## 4. Name of parts

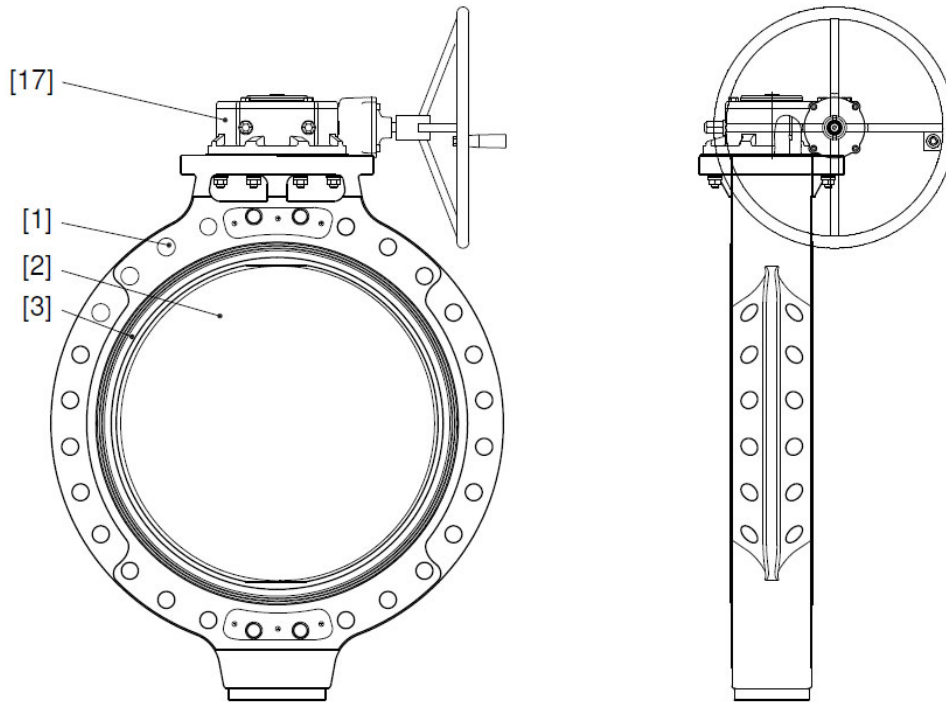

No.	Parts name	No.	Parts name
[1]	Body	[3]	Seat
[2]	Disc	[17]	Gearbox

## 5. Maximum allowable pressure and temperature

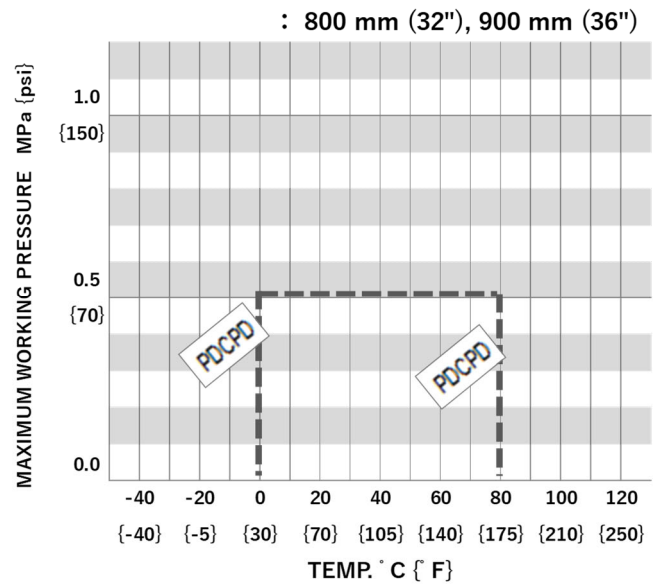
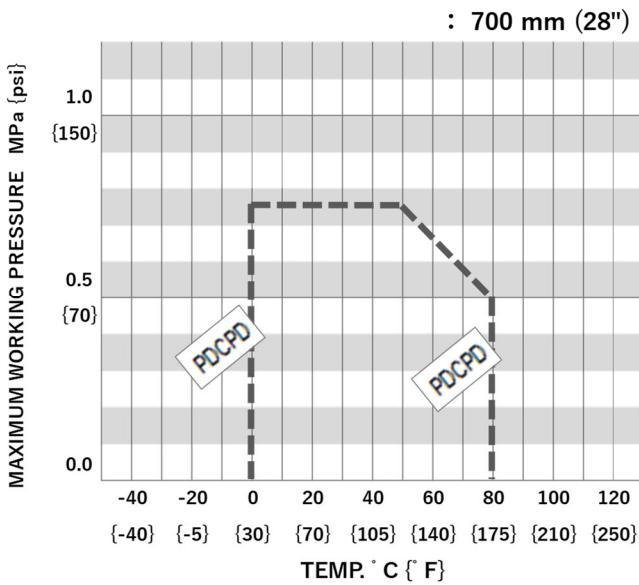

## 6. Installation procedure

### Warning



- When suspending and supporting a valve, take care and do not stand under a suspended valve.



- When lifting the valve, hang a nylon sling around the neck of the valve.

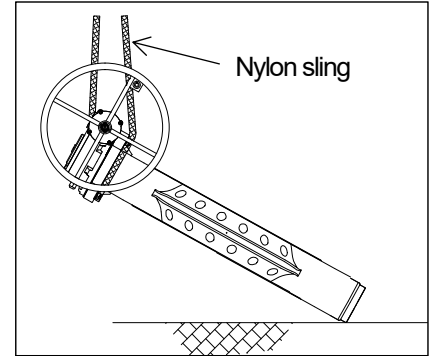

### Caution



- When installing a pipe support by means of a U-type clamp or something similar, take care not to over-tighten. (Excessive force may damage the pipe.)
- When piping the valve, do not install it in the fully closed state. (There is a risk that the disc will bite into the seat and the operating torque will become heavy, making it impossible to open and close.)
- Do not transport or piping the valve in the "No good" condition shown in Figure 6-1. The sealing surface of the disc will be damaged.
- Do not tighten the piping bolts and nuts above the specified torque value. (The valve may be damaged or leak.)
- Do not use an impact wrench to tighten piping bolts and nuts. (It may cause deformation or damage of valves and bolts.)



- Be sure to conduct a safety check on all hand and power tools to be used before beginning work.
- When conducting piping work, wear personal protective equipment appropriate to the contents of work. (Failure to do so may cause an injury.)
- When installing pipes and valves, ensure that they are not subjected to tension, compression, bending, impact, or other excessive stress.
- Use flat faced flanges for connection. If it is unavoidable to use a flange other than the flat flanges (flange adapter, backing flange, etc.), the flange corner may bite into the seat depending on the valve size, and the seat may be damaged, please contact the nearest sales office.
- Ensure that the mating flanges are of the same standards.
- Tighten the piping bolts and nuts through the through holes first to fix them. (If you tighten the stud bolts and nuts first, it may be damaged.)
- The gasket for piping is unnecessary. (The seat of valve carries out the role of the gasket.)

## ⚠ Caution

- The valve is shipping in the "good" state shown in Fig. 6-1. When operating the valve when installing piping, be sure to return the disc to its original state ("Good" in Fig. 6-1) after operation before installing. ( Failure to do so will result in damage to the surface of the disc during handling and installation.)
- Care must be used during piping installation to ensure that the pipes or flanges are properly aligned so that the valve disc does not contact them in any setting. Misalignment as in fig.6-2 will result in damage to the disc.
- In case of an abutting thick walled flange and pipe, shave the flange or the pipe inner diameter in order to avoid contact of pipe and disc. If the inside diameter of the connecting pipe is larger than dimension D below, shaving is not necessary. (Refer to fig.6-2.)

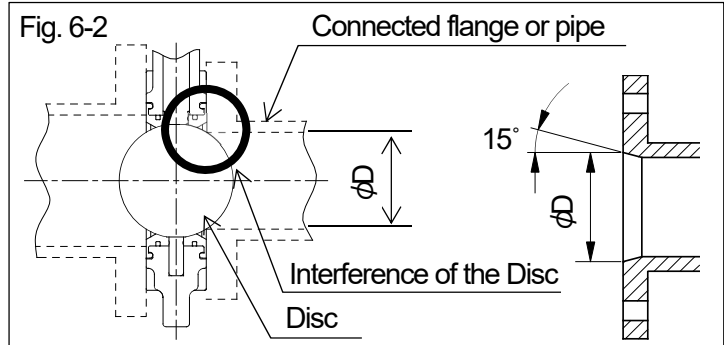
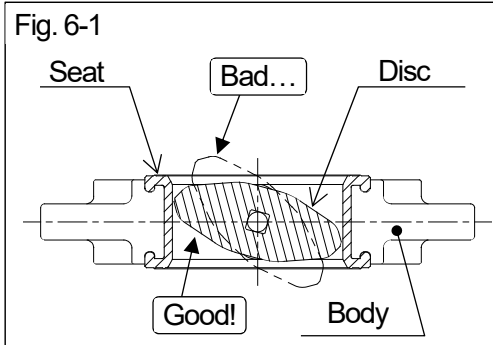

Table 6-1 Minimum inner diameter

Nominal size mm (inch)	700 (28")	800 (32")	900 (36")
$\phi D$ mm (inch)	667 (26.65")	777 (30.59")	877 (34.53")

- Necessary items:
- Torque wrench
  - Spanner wrench
  - Through bolt
  - Stud bolt (All screw type)
  - Nut, Washer, and Spring washer
  - Waste cloth
  - Adapter flange (When needed)

### Dimensions of through bolts and stud bolts

- The bolt length varies depending on the connection standard and flange material, so calculate the bolt length using the following formula.

- L : Through bolt length
- S : Thread length of through bolt
- L1: Stud bolt length
- D : Nominal diameter of screw
- W : Face-to-face dimension of valve
- a : Screw depth of valve side
- b : Flange thickness
- c : Washer thickness
- d : Nut height
- e : Bolt extension  
(3 times the thread pitch)

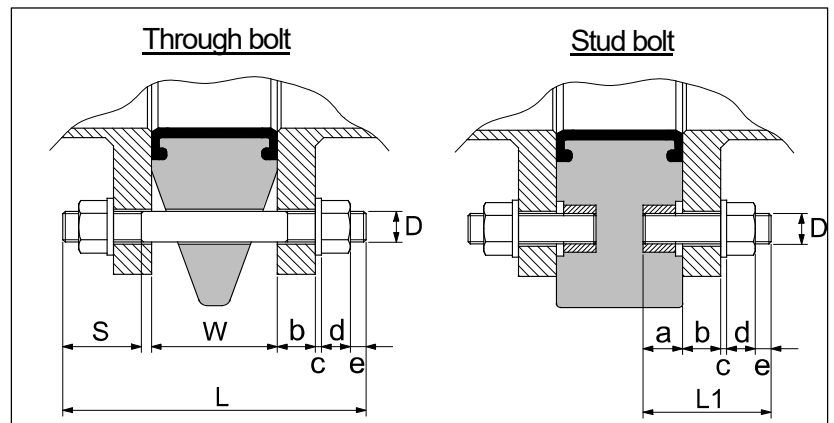

Through bolt:  $L \geq W + (b + c + d + e) \times 2$   
 $S \geq D \times 2.5$

Stud bolt:  $L1 \geq a + b + c + d + e$

Nominal size		Unit	700mm (28")	800mm (32")	900mm (36")	
Common	W	Face-to-face dimension of valve	mm (inch)	169 (6.65)	198 (7.80)	211 (8.31)
JIS10K	D	Nominal diameter of screw		M30	M30	M30
	a	Screw depth of valve side	mm (inch)	28 (1.10)	30 (1.18)	30
	quantity	Through bolt	(Book)	20	24	24
		Stud bolt	(Book)	8	8	8
		Nut	(pcs.)	48	56	56
Washer		(Sheet)	48	56	56	
DIN	D	Nominal diameter of screw		M27	M30	M30
	a	Screw depth of valve side	mm (inch)	28 (1.10)	30 (1.18)	30 (1.18)
	quantity	Through bolt	(Book)	20	20	24
		Stud bolt	(Book)	8	8	8
		Nut	(pcs.)	48	48	56
Washer		(Sheet)	48	48	56	
ANSI	D	Nominal diameter of screw		UNC 1½-7	UNC 1½-6	UNC 1½-6
	a	Screw depth of valve side	mm (inch)	28 (1.10)	30 (1.18)	30 (1.18)
	quantity	Through bolt	(Book)	24	24	28
		Stud bolt	(Book)	8	8	8
		Nut	(pcs.)	56	56	64
Washer		(Sheet)	56	56	64	

### Procedure

- Set the connecting flange in advance.  
Place the connecting flange on the pedestal so that the center of the valve and the center of the connecting flange are almost the same when the valve is raised, and wipe the flange surface of the connecting flange with a waste cloth.
- Stand the valve upright.  
Wrap a nylon sling around the neck of the valve to gradually raise the valve and wipe the inner surface of the valve with a waste cloth.
- Insert a valve between the connecting flanges and gradually lower it.
- Temporarily attach the valve to the connecting flange.  
Move the valve or connecting flange little by little so that the bolt holes in the connecting flange are roughly aligned with the bolt holes in the valve, attach the through bolts and stud bolts, and lightly tighten the nuts.
- After lightly installing all the bolts, gradually tighten only the through bolts diagonally to the specified torque value with a torque wrench.  
(Refer to Table 6-2 and Fig. 6-3)
- After tightening the through bolts, gradually tighten the screw-in bolts diagonally to the specified torque value with a torque wrench.  
(Refer to Table 6-2 and Fig. 6-3)
- Tighten all piping bolts clockwise to the specified torque value two turns or more.  
(Refer to Table 6-2 and Fig. 6-3)

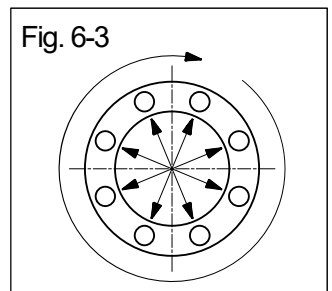
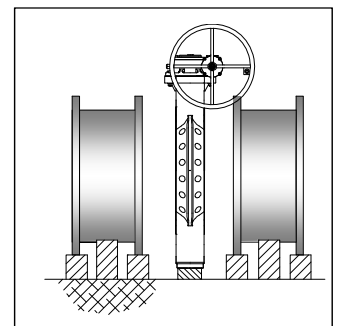
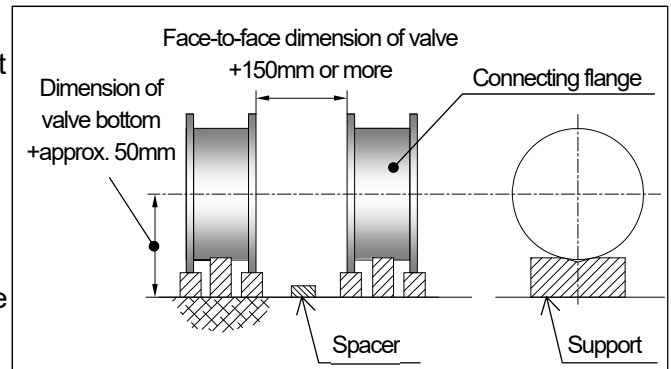

Table 6-2 Tightening torque

Nominal size mm (inch)	700 (28")	800 (32")	900 (36")
Tightening torque N-m {lbf-in}	130 {1,151}	130 {1,151}	170 {1,505}



## 7. Support setting procedure

### Caution



- Do not subject valve pump vibrations. (The valve may be damaged.)

Necessary items

• Spanner wrench

• U-type clamp (with bolt)

• Rubber sheet

#### Horizontal installation

- Set the stand under the valve.
- Place a rubber sheet under the gearbox, and support it with a stand.
- Place a rubber sheet on the pipe and fix the pipe with a U-type clamp.

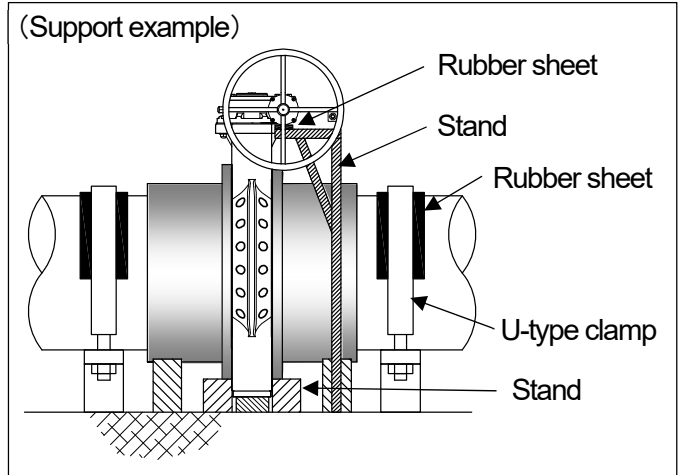

#### Vertical installation

- Set the stand under the gearbox.
- Place a rubber sheet under the gearbox, and support it with a stand.
- Place a rubber sheet on the pipe, and fix the pipe with a U-type clamp.

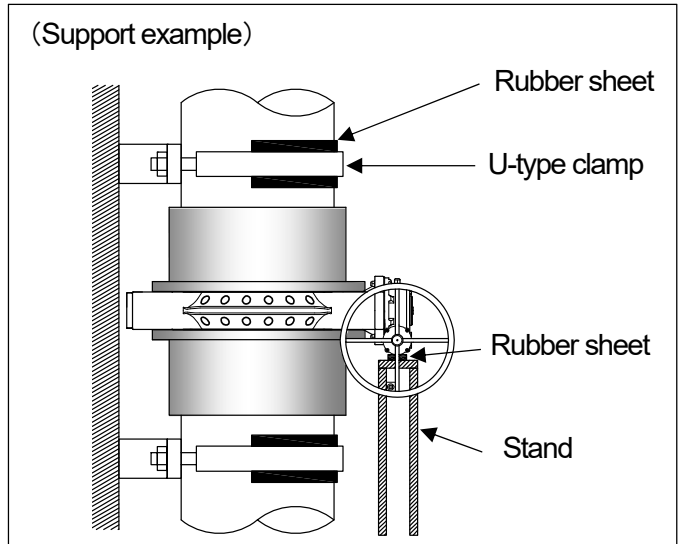

## 8. Operating procedure

### Caution



- Do not open/close with more than the maximum hand wheel operating torque. (Refer to table 8-1.)



- When operating the hand wheel, be sure to do so with your hand. (Using a tool may damage the hand wheel or gearbox.)

- Operate when the disc and seat are wet. (It may not work properly.)

#### Procedure

- 1) Slowly turn the hand wheel while checking the travel indicator on the top of the gearbox.

[Specifications that open counterclockwise]

- Turn the hand wheel clockwise : Close the valve
- Turn the hand wheel counterclockwise : Open the valve

[Specifications that open clockwise]

- Turn the hand wheel clockwise : Open the valve
- Turn the hand wheel counterclockwise : Close the valve

Table 8-1 Number of hand wheel rotations

Nominal size mm (inch)	700 (28")	800 (32")	900 (36")
Number of hand wheel rotation	55	87	87

## 9. Liquid flow and gearbox stopper adjustment procedure

### Caution



- Do not lose the resin washer attached to the lock nut.



- After adjustment of stopper, securely fix the cap nut so that it does not come loose. (Rainwater may enter the gearbox.)

### 9-1. Liquid flow

#### Procedure

- 1) Make sure there are no foreign objects in the pipe that could damage the seat and disc before the liquid flows, and full open the valve.

### 9-2. Gearbox stopper adjustment

\* The disc seal position has been adjusted, but if the valve leaks during operation, adjust the gearbox stopper bolt.

#### Necessary items

- Spanner wrench
- Allen wrench

#### Procedure

- 1) Remove the hexagon cap nut in the direction you want to adjust (full open or full close) with a spanner wrench counterclockwise.
- 2) Remove the resin washer attached to the stopper bolt.
- 3) Turn the stopper bolt with a hexagon wrench so that it does not come counterclockwise. (Approx. rotation of 2.)
- 4) Rotate the hand wheel of gearbox in the direction you want to adjust (full open or full close).
- 5) Turn the stopper bolt in the direction you want to adjust clockwise with a hex wrench until it stops.
- 6) Attach the resin washer to the stopper bolt.
- 7) Screw the hexagon cap nut into the stopper bolt clockwise by hand.
- 8) Screw the hexagon cap nut clockwise with a spanner wrench to the extent that the resin washer is not damaged. (Approx. rotation of 1/4)
- 9) Check if the stopper works with the proper position.

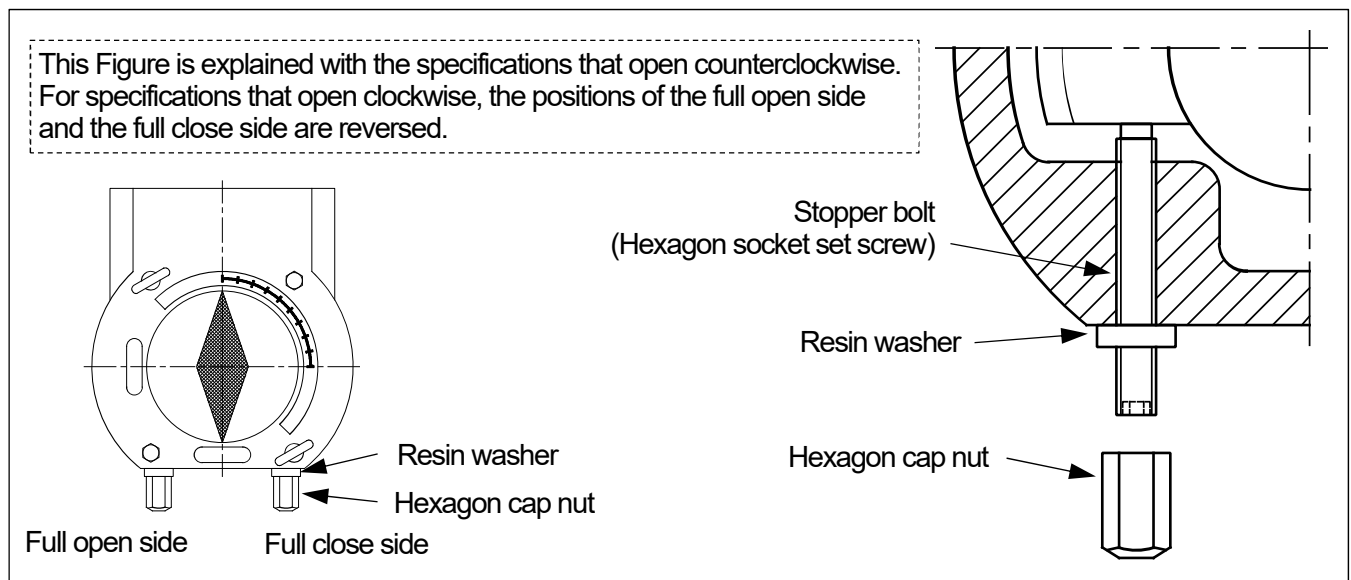

## 10. Inspection items

### Caution



- Please enforce daily inspection and periodic inspection. (Leakage may develop due to temperature changes or over periods of prolonged storage, rest or operation.)

#### 10-1. Daily inspection

Inspection item	The point of inspection	Inspection method	Coping
External leakage	- Flange piping connection	- Visual check	- Flange piping bolt retightening
	- Valve top flange (Mounting part of gearbox / actuator)	- Visual check	- Valve replacement (Please contact your nearest sales office.)
	- Valve bottom		
Internal leakage	- Leakage from secondary piping	- Visual check	- Stopper adjustment of gearbox
	- Instruments such as flow meters and pressure gauges	- Measurement	- Inspection cleaning - Valve replacement (Please contact your nearest sales office.)
Valve actuation	- Gearbox position deviation	- Visual check	- Stopper adjustment of gearbox
	- Hand wheel operation torque	- Operation feeling	- Gearbox or Valve replacement (Please contact your nearest sales office.)
Abnormal noise, vibration	- Valve body and gearbox - Piping around the valve, piping bolt	- Sound check - Visual check	- Removal of vibration source - Adjust valve opening (flow rate, pressure, etc.) - Fixing bolt retightening
Loose of fixing bolt	- Flange piping bolt - Gearbox and valve fixing bolt	- Finger touch - Visual check	- Fixing bolt retightening
Valve breakage	- Valve surface	- Visual check	- Valve replacement (Please contact your nearest sales office.)

#### 10-2. Routine inspection (Recommendation: Once a year)

Inspection item	The point of inspection	Inspection method	Coping
Seat wear damage	- Seat appearance	- Visual check (Valve removal)	- Valve replacement (Please contact your nearest sales office.)
Valve disc wear damage	- Valve disc appearance		

## 11. Troubleshooting

Trouble	Probable cause	Coping
Leak from flange pipe connection	Loose or uneven tighten of piping bolts	Reduce the internal pressure of the pipe, and retighten the bolts and nuts in a diagonal line. (Refer to “ <b>6. Installation procedure</b> ”.)
	Valve seat turning and damage	Remove the valve from the piping and check the seat for turning and damage. If there is an abnormality, replace the valve and reinstall. (Please consult with our nearest sales office or distributor.)
	Foreign matter adhesion, Flange seal surface damage	Remove the valve from the piping and check for damage to the flange seal surface and adhesion of foreign matter. If foreign matter adheres, clean the sealing surface and reinstall the valve. If it damaged, replace the valve and reinstall. (Please consult with our nearest sales office or distributor.)
	Flange and valve misalignment	Loosen the bolts, align the center of the valve and reinstall. (Refer to “ <b>6. Installation procedure</b> ”.)
Leakage from valve top flange or valve bottom	Wear and damage to the stem seal of the valve	Remove the valve from the piping, and replace the valve and reinstall. (Please consult with our nearest sales office or distributor.)
Leakage from valve seat	High fluid pressure	Check “ <b>5. Maximum allowable pressure and temperature</b> ” and use within the maximum allowable pressure.
	Damage to disc or seat due to foreign object biting	Remove the valve from the piping and check for foreign matter biting or damage to the disc and seat. If the damaged at disc and seat, replace the valve and reinstall. (Please consult with our nearest sales office or distributor.)
	Wear or damage to disc and seat	Remove the valve from the piping and check the disc and seat for wear or damage. If it wear or damage, replace the valve and reinstall. (Please consult with our nearest sales office or distributor.)
	Deviation of the valve disc fully closed position	Check the valve full close position with the indicator. If there is misalignment, adjust the full close stopper position of the gearbox. (Refer to “ <b>9. Liquid flow and gearbox stopper adjustment procedure</b> ”.)
	Loose or uneven tighten of piping bolts	Reduce the internal pressure of the pipe, and retighten the bolts and nuts in a diagonal line. (Refer to “ <b>6. Installation procedure</b> ”.)
	Seat wear and damage due to long-term use and frequent opening and closing	Remove the valve from the piping and check the seat for wear or damage. If it wear or damage, replace the valve and reinstall. (Please consult with our nearest sales office or distributor.)
	Abnormal rise in operating torque	Replace the valve and reinstall. (Please consult with our nearest sales office or distributor.)
	Overtightening the piping bolts	Reduce the internal pressure of the pipe and loosen the bolts and nuts, and retighten the bolts and nuts in a diagonal line. (Refer to “ <b>6. Installation procedure</b> ”.)

Trouble	Probable cause	Coping
The valve does not move  The valve does not operate smoothly  Hand wheel operation torque is heavy	Interference of the valve disc to the inner surface of the pipe	Remove the valve from the piping and check for damage to the disc. If the damaged at disc, replace the valve and reinstall. (Please consult with our nearest sales office or distributor.)
		Insert a spacer between the valve and the flange to prevent the valve body from interfering, and pay careful attention to the misalignment. (Please consult with our nearest sales office or distributor.)
	Overtightening or uneven tighten of piping bolts	Reduce the internal pressure of the pipe and loosen the bolts and nuts, and retighten the bolts and nuts in a diagonal line. (Refer to “ <b>6. Installation procedure</b> ”.)
	Abnormal rise in operating torque	Remove the valve from the piping and check for foreign matter biting or damage to the disc and seat. If the damaged at disc and seat, replace the valve and reinstall. (Please consult with our nearest sales office or distributor.)
	Interference of valve disc to seat turn	Remove the valve from the pipe and check the seat turn. If there is an abnormality, replace the valve and reinstall. (Please consult with our nearest sales office or distributor.)
	Damage to gearbox	Replace the gearbox. (Please consult with our nearest sales office or distributor.)
	Damage to valve parts	Replace the valve and reinstall. (Please consult with our nearest sales office or distributor.)
	Valve torque is heavy due to foreign object biting	Remove the valve from the piping and check for foreign matter biting or damage to the disc and seat. If the damaged at disc and seat, replace the valve and reinstall. (Please consult with our nearest sales office or distributor.)

## 12. Handling of residual and waste materials

### Warning



- Make sure to consult a waste treatment dealer for recommendations on the proper disposal of plastic valves. (Poisonous gas is generated when the valve is burned improperly.)

## Butterfly Valve Type 58 Side gear type 700mm (28") ~ 900mm(36")

**Asahi/America, Inc.**

---



**Distributor**

<https://www.asahi-america.com>