

TYPE-21 AND TYPE-23 MULTIPOINT™ BALL VALVE WITH SERIES 19 COM PACK® FAILSAFE ELECTRIC ACTUATOR



Standard Features (Sizes 1/2" - 2")

- **Compact:** Perfect for OEM and skid manufacturers with a footprint of 2.75" x 4" up to a 2" ball valve
- **Multi-voltage:** 95 VAC to 265 VAC or 24 VAC/VDC
- **Motor:** Reversing, brushless DC motor
- **Capacitor Discharge System:** A capacitor is used in place of batteries for failsafe mode
- **Fail Position:** Fail close is standard; fail open is an option
- **Gear Train:** Permanently lubricated steel gears
- **Corrosion Resistant Enclosure:** NEMA 4X PC/PET enclosure with stainless steel trim
- **ISO mounting configuration**
- **Electrical Connection:** NEMA 4X cable gland with two-meter cable
- **Position Indication:** Highly visible beacon position indicator
- **LED Position Indication:** RED closed, GREEN open
- **Manual Override:** Manually cycle valve via electroless nickel-plated hex key
- **Auxiliary Contacts:** Open and closed dry contacts rated 0.1 Amp @ 250 VAC, 0.5 Amp @ 30 VDC
- **Space Heater:** Internally wired to limit condensation
- **CE Compliant:** All actuators are CE labeled and compliant
- **75% Duty Cycle:** Extended duty cycle is ideal for high cycling applications
- **QR Code:** Links to user manual; includes wiring schematic
- **Simple Wiring:** Wiring technique is the same for all voltage units



Specifications

Motor Type:	Reversing, brushless DC
Sizes:	C20 for 1/2" - 2" valves
Torque:	177 in-lbs
Voltage:	95 VAC to 265 VAC multi-voltage
Amp Draw:	0.18 Amp
Max Ambient Temp:	150° F
Enclosure:	NEMA 4X

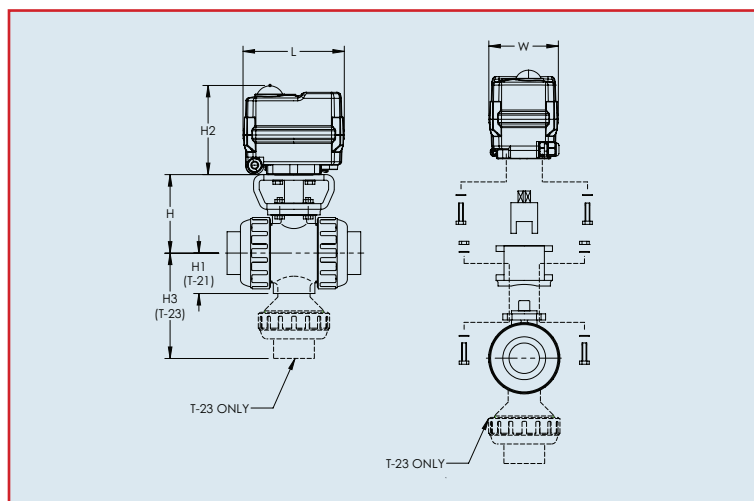

Dimensions (inch)

Size	1/2"	3/4"	1"	1-1/4"	1-1/2"	2"
H	2.76	3.01	3.29	3.64	3.98	4.43
H1	1.14	1.38	1.54	1.85	2.17	2.60
H2	3.54	3.54	3.54	3.54	3.54	3.54
H3	3.08	3.56	4.32	N/A	5.71	6.66
L	4.01	4.01	4.01	4.01	4.01	4.01
W	2.76	2.76	2.76	2.76	2.76	2.76
Model	C20	C20	C20	C20	C20	C20

Weight (lbs)

Size	1/2"	3/4"	1"	1-1/4"	1-1/2"	2"
Weight	2.7	2.9	3.4	3.8	4.9	6.7

Engineering Data

Model	Torque (in-lbs)	95 - 265 VAC		24 VAC/VDC		Cycle time per 90 degrees [seconds] *
		Amp Draw	Duty Cycle	Amp Draw	Duty Cycle	
C20	177	0.18	75%	0.96	75%	10

Amp draw is considered locked rotor

*Cycle times are approximate

Duty cycle shown for ambient temp (73° F)

TYPE-21 AND TYPE-23 MULTIPOINT™ BALL VALVE WITH SERIES 19 COM PACK® FAILSAFE ELECTRIC ACTUATOR

Wiring Diagram

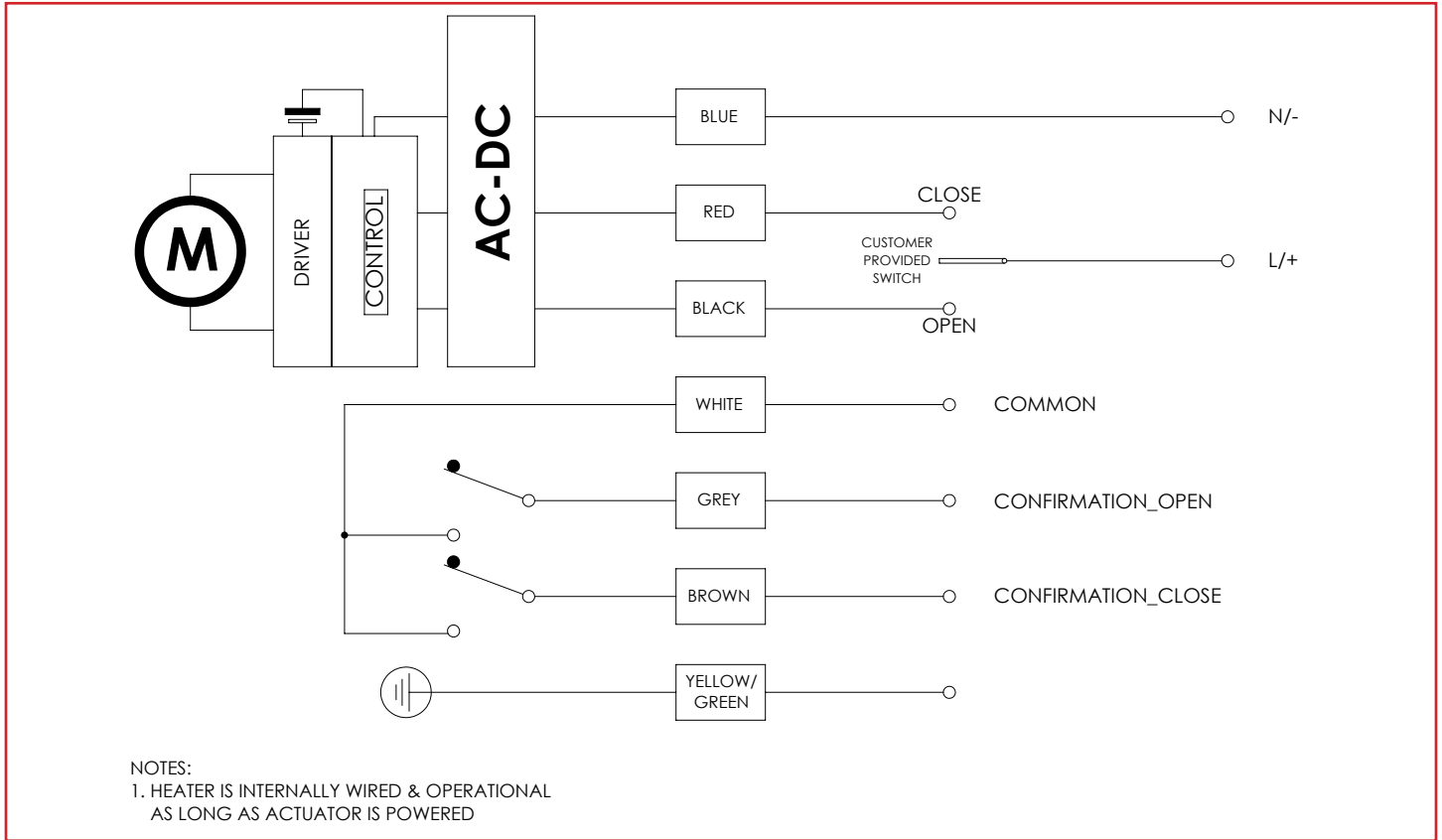

Sample Specifications

All Series 19 CAV failsafe electric actuators shall have a brushless DC motor that accepts multiple voltages, permanently lubricated steel gears, NEMA 4X PC/PET enclosure with stainless steel trim, visual beacon indication, ISO 5211 valve mounting platform, manual override, and be CE compliant. Actuator shall be of capacitor discharge design with no batteries, and be standard as fail close upon loss of supply power. Standard features shall include a heater, one set of dry contacts for PLC confirmation, LED position indicator, and a QR code that links to its user manual and wiring schematic.

Series 19 Actuator Selection Guide

Valve	Valve Size	C20	S20	S50	S110
Omni® Type-27 Ball Valves	3/8" - 2"	X			
Type-21/21a SST Ball Valves	1/2" - 2"	X	X		
	2-1/2" - 3"			X	
Type-23 Multipoint™ Valves	4"				X
	1/2" - 2"	X	X		
	3"			X	
Type-57P Butterfly Valves	4"				X
	1-1/2" - 2-1/2"		X		
	3" - 4"			X	
	5" - 6"				X

