

# Series 92 & 94 Wiring Schematics

## Wiring Diagram for 115 VAC or 230 VAC Units

Actuator Shown is Counter-Clockwise Extreme of Travel, or "Open" Position

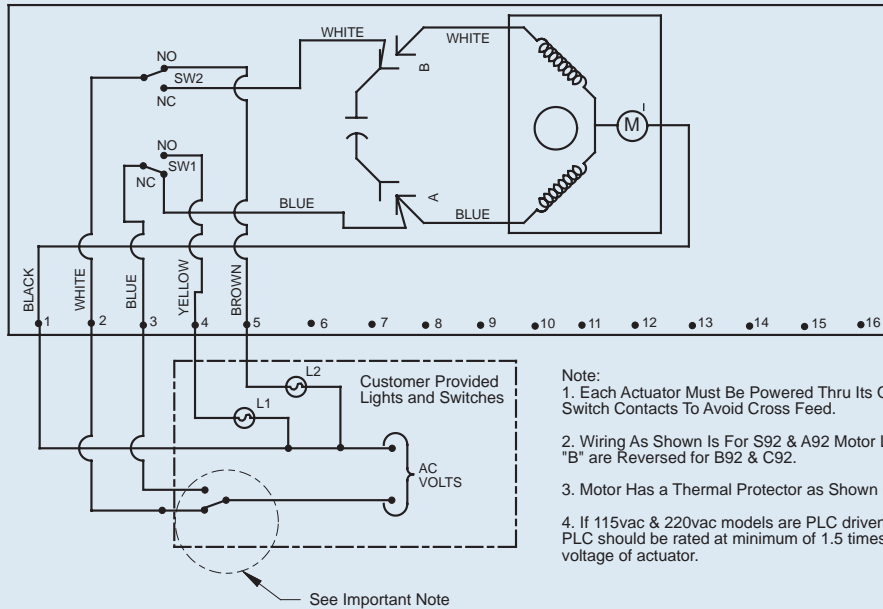

- Note:
1. Each Actuator Must Be Powered Thru Its Own Individual Switch Contacts To Avoid Cross Feed.
  2. Wiring As Shown Is For S92 & A92 Motor Leads at "A" And "B" are Reversed for B92 & C92.
  3. Motor Has a Thermal Protector as Shown By (M) in Diagram.
  4. If 115vac & 220vac models are PLC driven, output contacts of PLC should be rated at minimum of 1.5 times required input voltage of actuator.

## Wiring for Optional Equipment

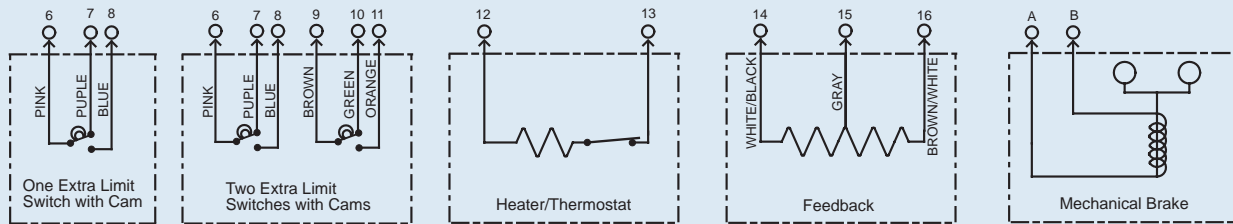

## Wiring Diagram for 12 VAC & 24 VAC Units

Actuator shown in counter-clockwise extreme of travel, or "OPEN" Position

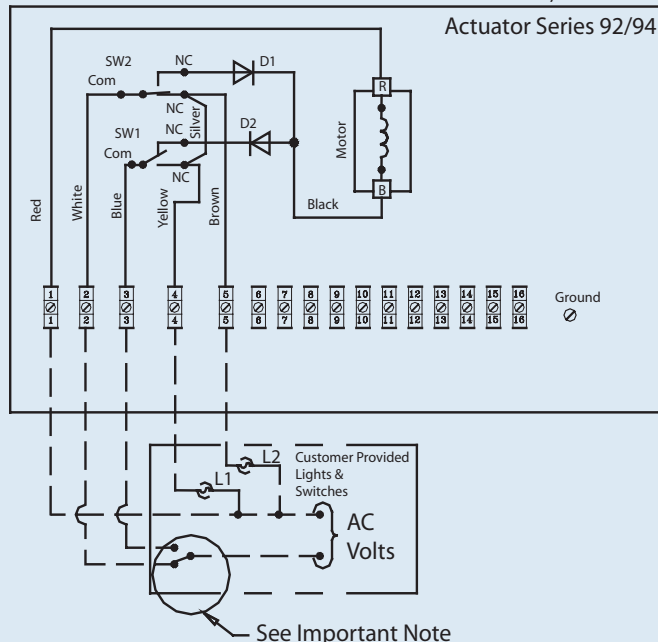

- Notes:
1. Each Actuator must be powered thru its own individual switch contact to avoid cross feed
  2. Motor leads are reversed for 1100 & 2000 in/lb actuator

Switch Location Viewed from Terminal Strip Front

- SW-2 - Open  
SW-1 - Close

# Series 92, 94 & 10 Wiring Schematics

Series 10 120\1\60 wiring

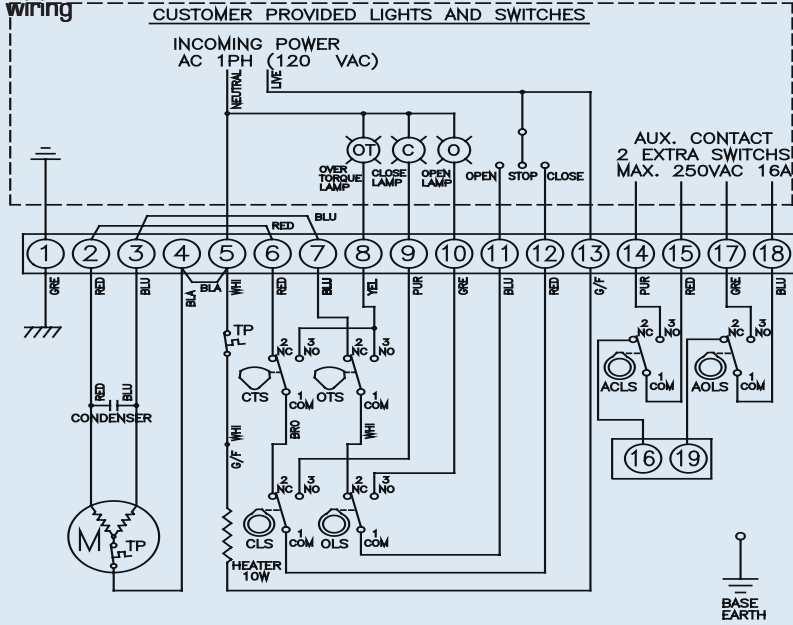

1. EACH ACTUATOR MUST BE POWERED THROUGH ITS OWN SET OF CONTACTS TO AVOID CROSS FEED.
2. MOTOR HAS A THERMAL PROTECTOR.
3. IF 120VAC OR 230 VAC MODELS ARE PLC DRIVEN, OUTPUT CONTACTS OF PLC SHOULD BE RATED AT A MINIMUM OF 1.5 TIMES THE REQUIRED INPUT VOLTAGE OF THE ACTUATOR.

Series 92/94

## Wiring Diagram for 12 VDC & 24 VDC Units

Actuator Shown is Counter-Clockwise Extreme of Travel, or "Open" Position

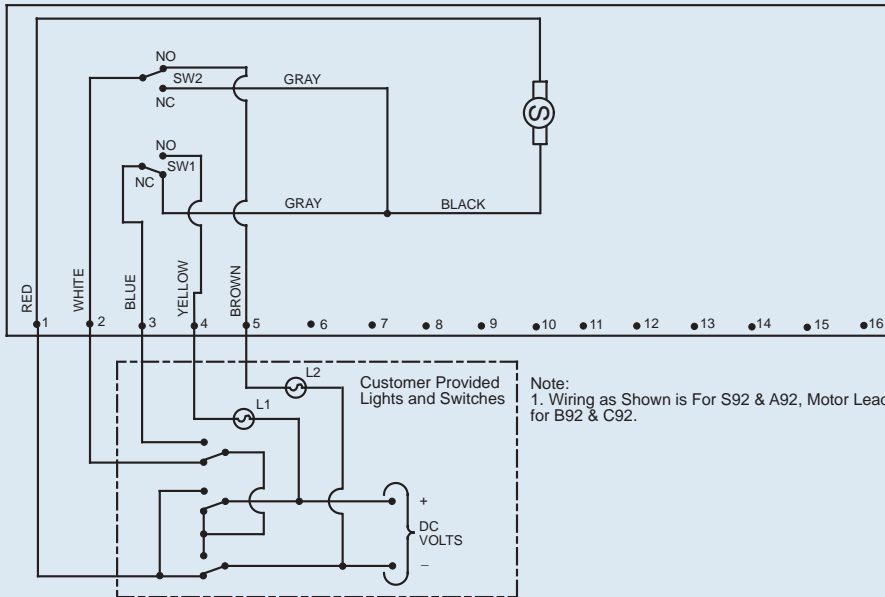

Note:  
1. Wiring as Shown is For S92 & A92, Motor Leads are Reversed for B92 & C92.