

LOCAL REMOTE STATION FOR ON/OFF SERIES 19 ELECTRIC ACTUATOR

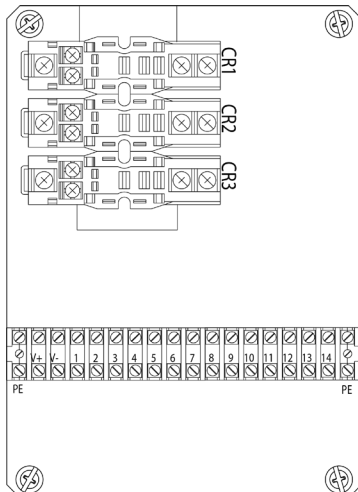

STANDARD FEATURES:

- NEMA Type 4X enclosure
 - Fiberglass polyester
 - Compact 8" x 6" x 4"
 - Stainless steel trim
- Captive cover gasket
- Captive cover screws
- 2- Position selector switch
 - Open
 - Close
- 3-Position selector switch
 - Hand
 - Off
 - Auto
- Terminal block for the landing of the Series 19 electric actuator flying leads
- 3-Indication lights
 - Green - open
 - Red - closed
 - Blue - alarm
- 3-Dry Contact Relays – SPDT, 10A
 - Open confirmation (CR1)
 - Closed confirmation (CR2)
 - Alarm (CR3)

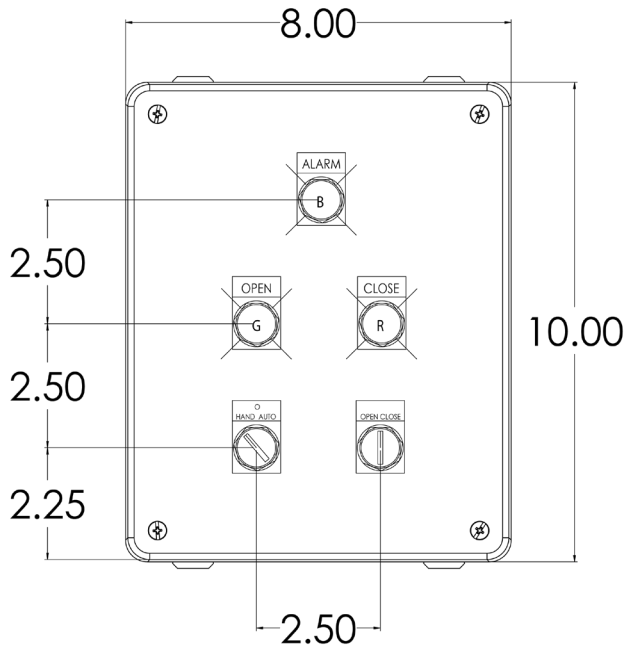