

## Diaphragm Valves

### AD-16 Compact Valves

- Compact design for tight installations
- Robust design for high cycle life
- Ideal for OEM equipment and skids
- Highly configurable options

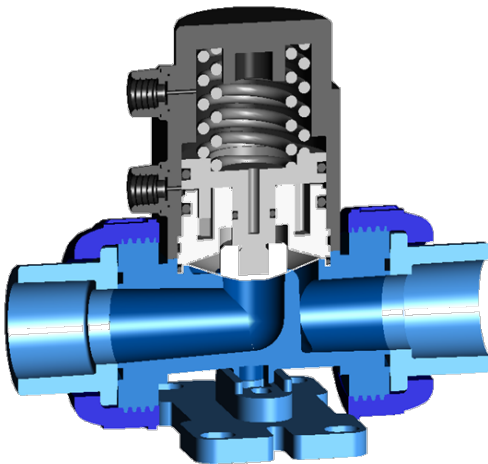

### Specifications

- Size Range:** 1/2" to 2"
- Body:** PVC
- Diaphragm:** PTFE (Stock), EPDM (Special Order)
- O-rings:** FKM, EPDM
- Connections:** IPS Socket, Female NPT  
Flanged (All True Union)
- Operation:** Air-Spring Closed, Air-Air  
Air-Spring Open
- Pilot Port:** 1/8" FNPT
- Max Pressure:** 72.5psi (1/2" to 1") and 58psi (1-1/4" to 2")
- Max Temp.:** 30-122° F

### Options

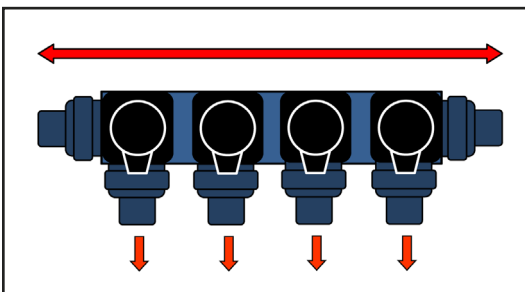

Custom Manifolds

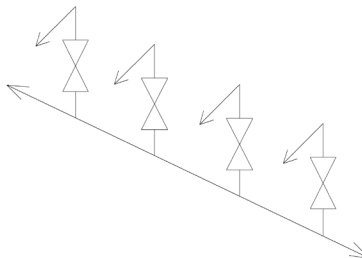

Travel Stop

## Dimensions

Size	Flanged	Threaded	Socket	H	W	P
	L	L	L			
1/2	6.22	4.61	4.65	3.11	1.97	2.48
3/4	7.52	5.47	5.43	4.25	2.36	2.87
1	8.09	5.87	5.89	4.29	2.36	2.87
1-1/2	10.39	8.46	8.50	6.36	3.74	4.23
2	11.69	10.24	10.24	7.42	4.53	5.04

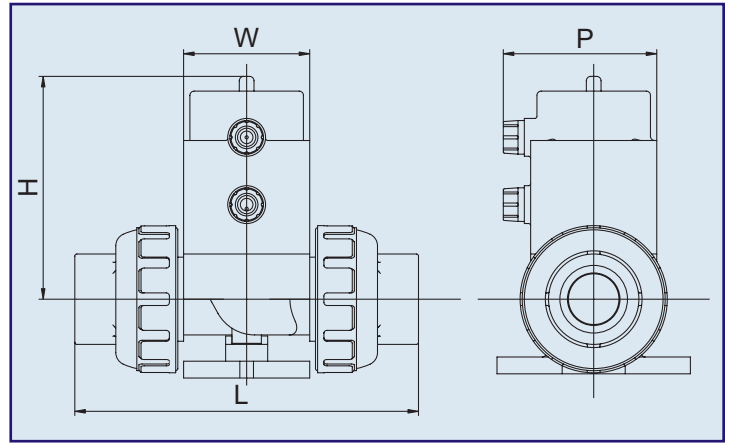

## Cv Values

Size	Cv Values
1/2	4.8
3/4	8
1	9.5
1-1/2	26
2	44

## Part Numbers

### Air to Spring Normally Closed Diaphragm Valve PTFE Diaphragm/EPDM O-rings

Size	IPS Socket Part Number	FNPT Part Number	Flanged Part Number
1/2"	841067005	841068005	841069005
3/4"	841067007	841068007	841069007
1"	841067010	841068010	841069010
1-1/2"	841067015	841068015	841069015
2"	841067020	841068020	841069020

### Air to Air Diaphragm Valve PTFE Diaphragm/EPDM O-rings

Size	IPS Socket Part Number	FNPT Part Number	Flanged Part Number
1/2"	841073005	841074005	841075005
3/4"	841073007	841074007	841075007
1"	841073010	841074010	841075010
1-1/2"	841073015	841074015	841075015
2"	841073020	841074020	841075020

### Air to Spring Normally Closed Diaphragm Valve PTFE Diaphragm/FKM O-rings

Size	IPS Socket Part Number	FNPT Part Number	Flanged Part Number
1/2"	841070005	841071005	841072005
3/4"	841070007	841071007	841072007
1"	841070010	841071010	841072010
1-1/2"	841070015	841071015	841072015
2"	841070020	841071020	841072020

### Air to Air Diaphragm Valve PTFE Diaphragm/FKM O-rings

Size	IPS Socket Part Number	FNPT Part Number	Flanged Part Number
1/2"	841076005	841077005	841078005
3/4"	841076007	841077007	841078007
1"	841076010	841077010	841078010
1-1/2"	841076015	841077015	841078015
2"	841076020	841077020	841078020

## Pressure Charts

### Working Pressure vs. Operating Pressure

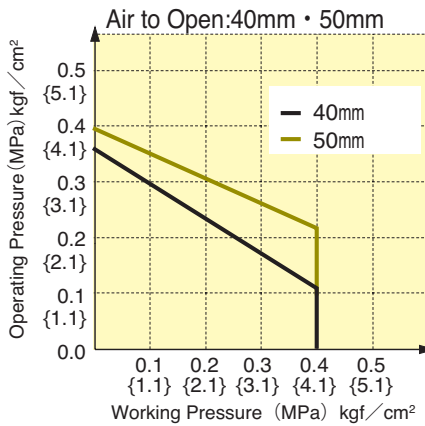
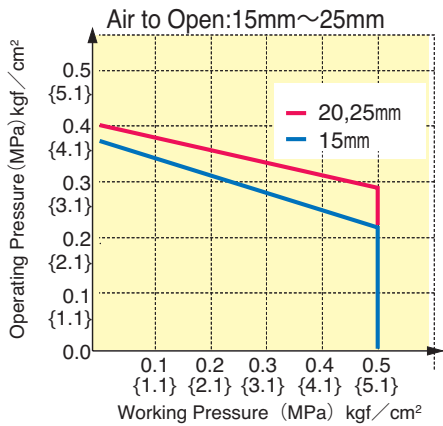
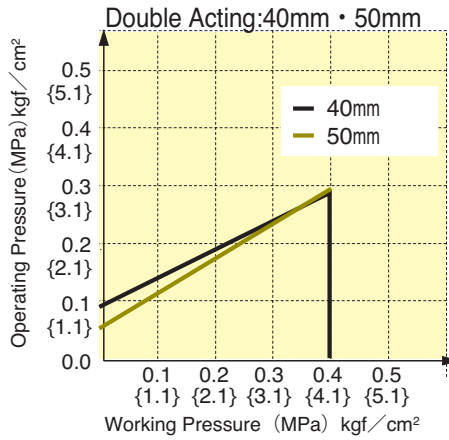
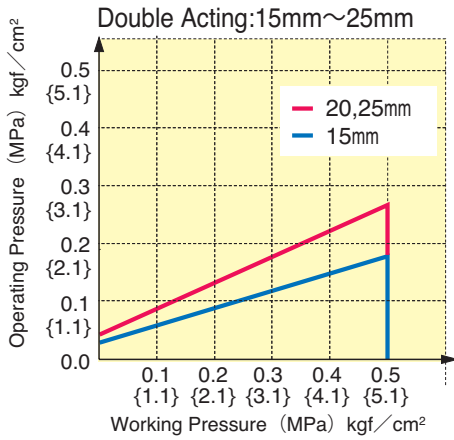

### Working Pressure vs. Temperature

