

Inductive Switches



Inductive Sensor	2 x NO Contacts
Operating Voltage	10 - 36 vdc
Current Rating (mA)	250
Reverse Polarity Protection	yes
Overload Protection	yes
Voltage Drop	< 2.5
Current Consumption (mA)	< 15 (24V)
Temperature (F)	- 13F - 175F
Protection	IP 67 (Type 6)
Materials	PBT/SS
Status Indicators	2 x Yellow LED
Connection	M12 Connector

Standard Features

- Low profile
- Engineered resin with SS trim
- 2-SPST N/O (PNP) hermetically sealed inductive switches
- M12 connection
- Visual position indication
- Low current consumption
- Temperature limit of 175 F

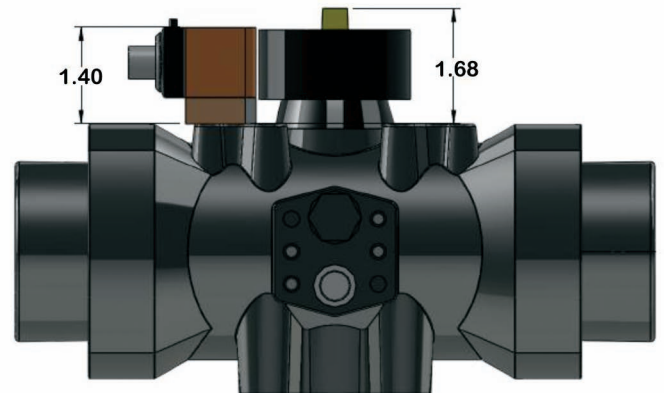

Options

- Patch cable (M12F x M12M)
 - Industrial - General Purpose
 - Sanitary - Wash down
 - Hazardous Environment
 - .3M, .6M, 1M, 2M, 5M Lengths
 - Straight or Angled
- Cord set (M12F x Flying Leads)
 - Industrial - General Purpose
 - Sanitary - Wash down
 - Hazardous Environment
 - 2M, 5M, 10M Lengths
 - Straight or Angled

