



Standard Features (Sizes 3" – 12")

- Standard model (3" – 12") has PVC Body and PP Disc for superior chemical resistance and elevated temperature capabilities.
- Our 316 stainless steel shaft has full engagement over the entire length of the disc and is a non-wetted part, totally isolated from the media.
- Only solid and abrasion-resistant plastic disc and elastomeric liner are wetted parts.
- ISO bolt circle on top flange– no body or stem modifications required for accessories.
- Stem retainer-PP retainer to prevent stem removal.
- Seat over tightening protection-molded body stops and seat stress relief area.
- Spherical disc design offers increased Cv, ultimate sealing and high cycle life.
- 304SS or 316SS Factory installed Lugs.

Options

- Pneumatically and electrically actuated with accessories
- Alternate discs:
 - (I) PVC : 3" – 12"
 - (II) PVDF : 3" – 12"
- Plasgear™ gear operators for 3"– 12"
- Stems in 316 stainless steel, titanium, Hastelloy C®.
- 2" square nut on stem (3" - 8" only)
- 2" square nut on gear operator (All sizes)

Specifications

Sizes: Lever: 3" – 8"
Gear: 8" – 12"

Models: Lug Style

Operators: Lever and Gear

Body: PVC

Discs: PVC, PP and PVDF

Seats: EPDM, FKM and Nitrile

Seals: Same as seating material

Stems: 316 stainless steel, Titanium, Hastelloy C®‡

‡ Trademark of Cabot Corporation

Parts List (Lever: Sizes 3" – 8")

PARTS			
NO.	DESCRIPTION	PCS.	MATERIAL
1	Body	1	PVC
1a	Lug	-	Stainless Steel 304, 316
2	Disc	1	PVC, PP, PVDF
3	Seat	1	EPDM, FKM, NBR
6	O-Ring (C)	1	EPDM, FKM, NBR
7	Stem	1	Stainless Steel 316
8	Stem Retainer	1	PP
16	Handle	1	PP
16a	Metal Insert in Handle	1	Stainless Steel 316L
17	Handle Lever	1	PPG
18	Pin	1	PPG
19	Spring	1	Stainless Steel 304
20	Washer (A)	1	Stainless Steel 304
21	Bolt (B)	1	Stainless Steel 304
22	Locking Plate	1	PPG
23	Screw (B)	4	Stainless Steel 304
24	Cap (A)	1	PP
156	Stabilization Ring	2	Stainless Steel (SCS13)
157	Screw (F)	4	Stainless Steel 304

- Stem extensions (single stem and two-piece stem)
- Locking devices (Gear Type – Standard on Lever)
- Chain operators
- Manual limit switch - Asahi P-Series
- Tandem arrangements (Patented by A/A, Inc.)



Type 57L Lug Guard Lever Butterfly Valve

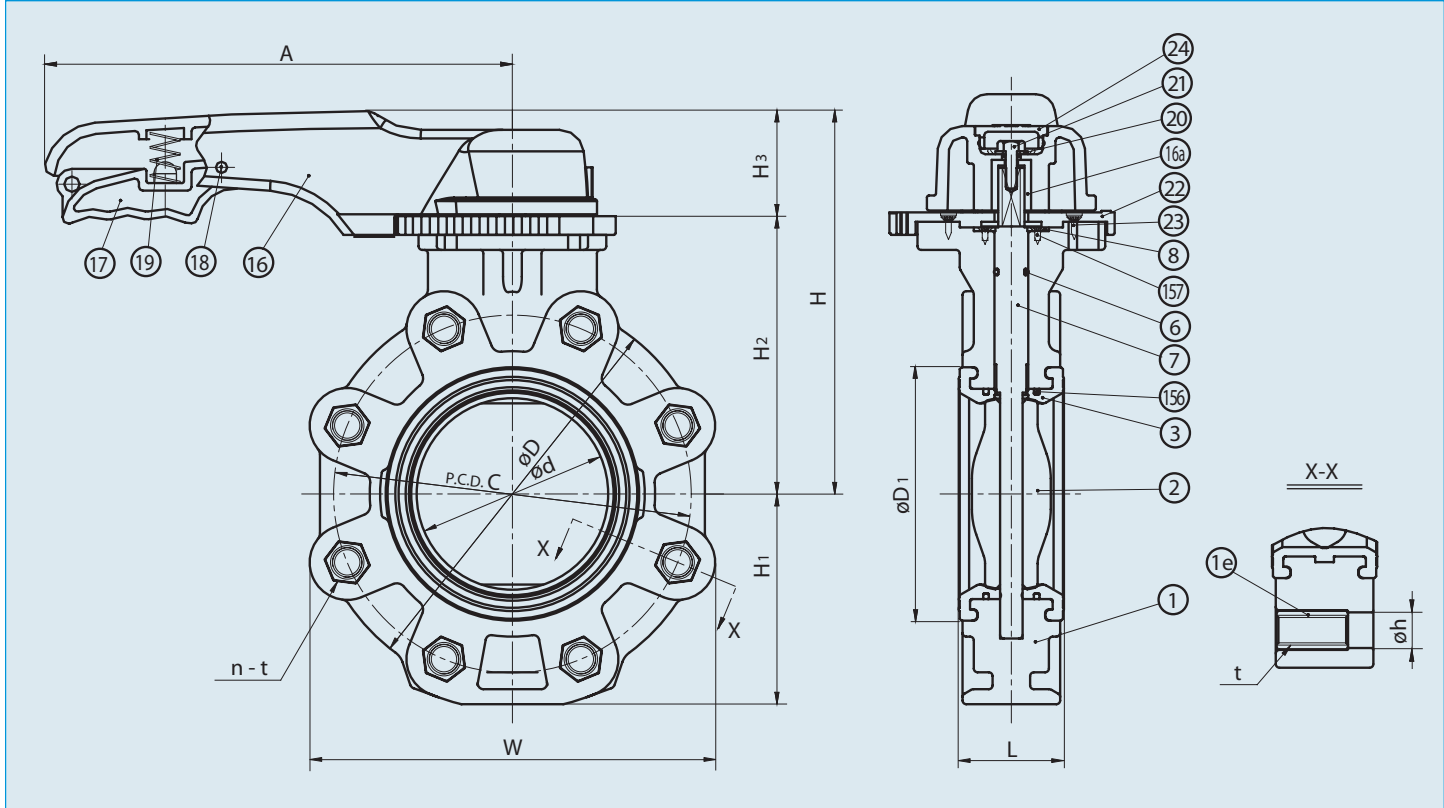

Dimensions (Lever: Sizes 3" - 8")

NOMINAL SIZE		ANSI CLASS 150															
INCHES	mm	d	C	n	h	D	D1	L	H	H1	H2	H3	A	W	t		
3	80	3.03	6.00	4	0.75	8.31	4.17	1.81	7.52	4.15	5.31	2.20	9.84	7.09	5/8-11UNC		
4	100	4.02	7.50	8	0.75	9.37	5.31	2.20	8.11	4.69	5.91	2.20	9.84	8.50	5/8-11UNC		
6	150	5.91	9.50	8	0.88	11.22	7.52	2.80	9.92	5.61	7.20	2.72	12.60	10.67	3/4-10UNC		
8	200	7.68	11.75	8	0.88	13.39	9.53	3.43	11.14	6.69	8.43	2.72	15.75	12.76	3/4-10UNC		

Wt (LBS)

NOMINAL SIZE		LEVER OPERATED	GEAR OPERATED
INCHES	mm		
3	80	5	10
4	100	7	12
6	150	15	20
8	200	25	30
10	250	n/a	41
12	300	n/a	76

Vacuum

NOMINAL SIZE		VACUUM SERVICE (INCHES OF MERCURY)
INCHES	mm	
3	80	-29.92
4	100	-29.92
6	150	-29.92
8	200	-29.92
10	250	-29.92
12	300	-24.37

Press vs. Temp

BODY		PVC		
DISC		PP		
NOMINAL SIZE		30° F	121° F	141° F
		120° F	140° F	175° F
INCHES	mm			
3	80	150	70	30
4	100	150	45	30
6	150	150	45	30
8	200	150	40	20

Cv Values

NOMINAL SIZE		Cv		
		(at various opening degrees)		
INCHES	mm	30°	60°	90°
3	80	18	183	300
4	100	28	287	470
6	150	66	671	1100
8	200	150	1525	2500
10	250	232	2355	3860
12	300	342	3477	5700



Type 57L Lug Guard Gear Butterfly Valve

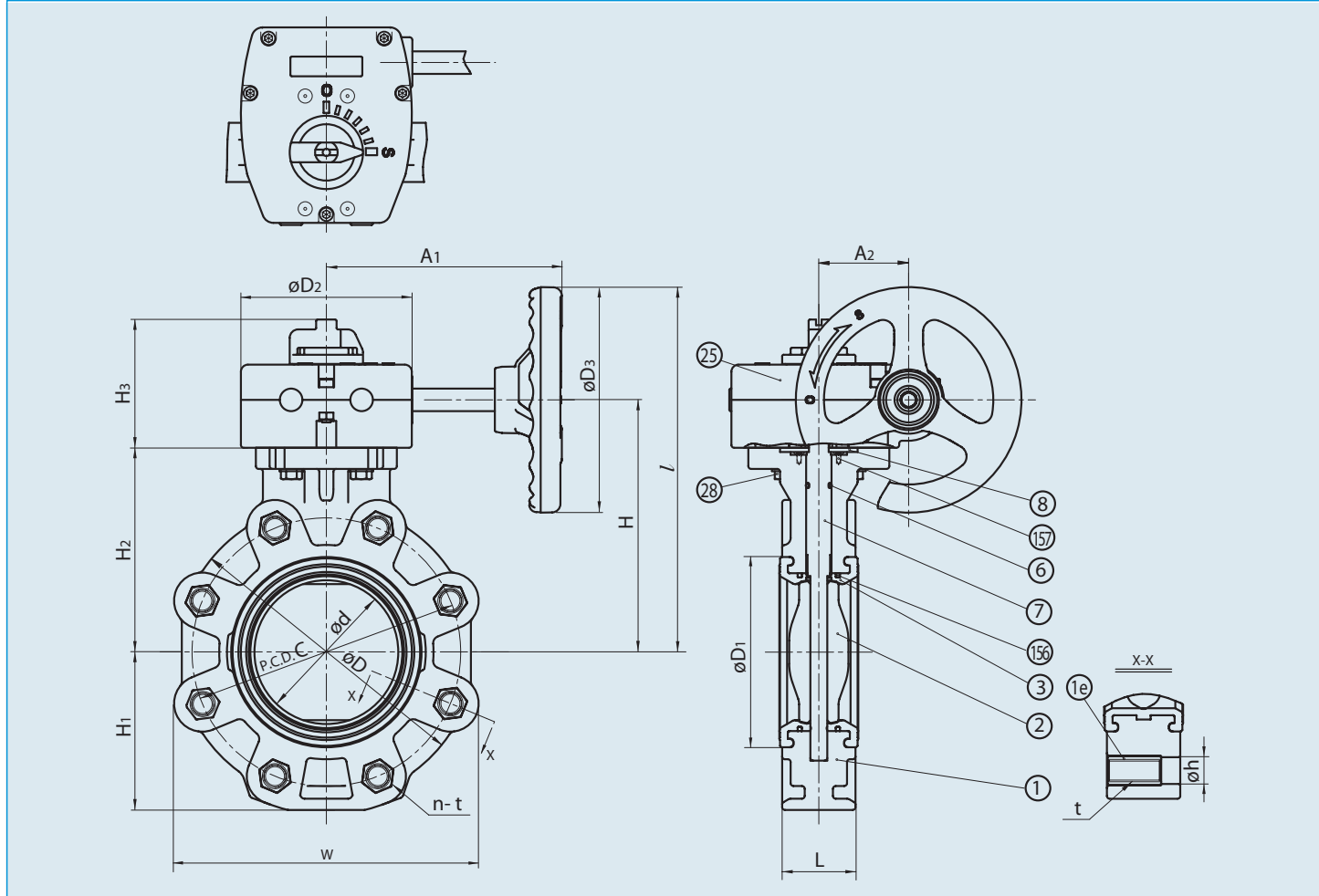

Dimensions (Gear: Sizes 3" - 12")

NOMINAL SIZE		ANSI CLASS 150															Wheel Cycles	Gear box model no.			
INCHES	mm	d	C	n	h	D	D1	D2	D3	L	H	H1	H2	H3	l	A1	A2	W	t		
3	80	3.03	6.00	4	0.75	8.31	4.17	4.80	6.30	1.81	6.50	4.15	5.12	3.54	9.65	6.57	2.52	7.09	5/8-11UNC	9.5	241
4	100	4.02	7.50	8	0.75	9.37	5.31	4.80	6.30	2.20	7.09	4.69	5.71	3.54	10.24	6.57	2.52	8.50	5/8-11UNC	9.5	
6	150	5.91	9.50	8	0.88	11.22	7.52	4.80	6.30	2.80	8.27	5.61	6.89	3.54	11.42	6.57	2.52	10.67	3/4-10UNC	9.5	
8	200	7.68	11.75	8	0.88	13.39	9.53	4.80	6.30	3.43	9.49	6.69	8.11	3.54	12.64	6.57	2.52	12.76	3/4-10UNC	9.5	
10	250	9.92	14.25	12	1.00	15.75	11.89	4.80	6.30	4.33	10.87	7.95	9.49	3.54	14.01	6.57	2.52	15.91	7/8-9UNC	9.5	
12	300	11.93	17.00	12	1.00	18.31	14.17	7.40	11.81	5.08	13.39	9.29	11.73	4.19	19.27	9.53	3.90	18.54	7/8-9UNC	9.5	243

Parts List (Gear)

PARTS			
NO.	DESCRIPTION	PCS.	MATERIAL
1	Body	1	PVC
1a	Lug	-	Stainless Steel 304, 316
2	Disc	1	PVC, PP, PVDF
3	Seat	1	EPDM, FKM, NBR
6	O-Ring (C)	1	EPDM, FKM, NBR
7	Stem	1	Stainless Steel 316
8	Stem Retainer	1	PP
25	Gear Box	1	Plasgear™
28	Bolt (C)	4	Stainless Steel 304
156	Stabilization Ring	2	Stainless Steel (SCS13)
157	Screw (F)	4	Stainless Steel 304

Press vs. Temp

BODY		PVC		
DISC		PP		
NOMINAL SIZE		30° F	121° F	141° F
		120° F	140° F	175° F
INCHES	mm			
8	200	150	40	20
10	250	150	40	20
12	300	100	30	15

Type 57L Lug Guard Butterfly Valve

Troubleshooting

What if fluid still flows when valve is closed?

1. Make sure lever or gear is in a fully closed position (gear type may require travel stop adjustment).
2. Liner is damaged or worn. Replace liner.
3. Disc is damaged or abraded. Change disc.
4. Foreign material is caught between seat and disc. Remove the substance.
5. Mating flange bolts either over-tightened or unevenly tightened. Retighten properly.

What if fluid leaks outside between seat and mating flange?

1. Seat damage. Change seat.
2. Mating flange bolts not tightened with proper torque or unevenly tightened. Retighten to the appropriate torque.

What if valve does not operate smoothly?

1. Foreign material is caught between disc and seat. Remove the material and clean.
2. Lever or gearbox is damaged. Replace.
3. Mating flange bolts over-tightened. Retighten.

Sample Specification

All solid thermoplastic butterfly valves sizes 3" thru 12" shall be of the TYPE 57L PVC lined body design and bubble-tight seal (meeting or exceeding Class VI as defined by American National Standard Institute) with only the liner and disc as wetted parts. The lever handle (sizes 3" thru 8") shall have a molded provision for a padlock. Gear operators shall be worm gear design, self locking Plasgear™. The spherical disc design for higher Cv values shall be of solid abrasion-resistant plastic. Liner shall be molded and formed around the body, functioning as gasket seals with convex ring design on each side of the valve for lower bolt tightening torque and valve body shall have molded body stops and seat relief area to prevent overtightening of mating flanges. Valves shall be molded to accept either 304 SS or 316 SS A/A factory produced lug inserts. Valve shall be capable of having down stream flange removed, while maintaining full line pressure on upstream side for end of line service. Stem shall be of 316 stainless steel, non wetted and have engagement over the full length of the disc. Valves shall have a molded ISO bolt pattern on top flange for actuator mount. PVC shall conform to ASTM D1784 Cell Classification 12454-A, PP conforming to ASTM D4101 Cell Classification PPO210B67272, and All (3" thru 10"), valves shall be rated to 150 psi and 12" rated to 100 psi, Butterfly valves shall be lug style, as manufactured by Asahi/America.