

# ASAHI/AMERICA

## Operation Manual for T342 & T343 Diaphragm Valves



35 Green Street, PO Box 653, Malden, MA 02148  
Tel: (800) 343-3618 - (781) 321-5409 - Fax (781) 321-4421  
[www.asahi-america.com](http://www.asahi-america.com) - [asahi@asahi-america.com](mailto:asahi@asahi-america.com)

## Components

1. The main components of the T342 & 343 valves are shown in Figure 1
2. The valve body is a molded component made from either **PolyPure** PPn, **PP-Pure** pigmented PP, or **Purad** PVDF.
3. The hand wheel is used to open and close the valve by contracting/retracting the diaphragm.
4. The position indicator rises/sinks proportionally to number of turns on the hand wheel.
5. The wheel lock is used to secure the hand wheel and diaphragm in a "locked" position.



Figure 1: Valve components

1. Positioning bolt w/ spring
2. Indicator cover
3. Indication disc
4. O-ring gasket
5. Circlip
6. Handle
7. PTFE-shim
8. Hex-nut cover
9. Hex-screws
10. Shims
11. O-ring gasket
12. Bonnet
13. Screen socket
14. Indicator
15. Spindle
16. Space-ring
17. Compressor
18. Dowel pin
19. Diaphragm
20. Hex-nuts
21. Threaded inserts
22. Body
23. Mounting plate

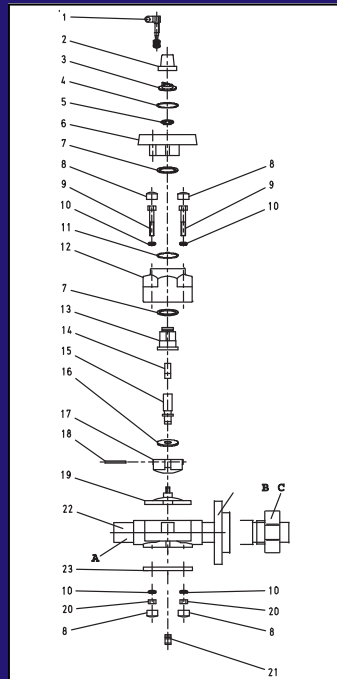

## Assembly

1. Push space-ring (16) & compressor (17) on spindle (15) & connect with dowel pin (18).
2. Screw screen socket (13) on lubricated spindle (15).
3. Push PTFE-shim (7) on screen socket (13)
4. Place finished unit (7,13-18) into bonnet (12)
5. Insert o-ring gasket (11) and PTFE-shim (7) in bonnet (12)
6. Snap positioning bolt with spring (1) into handle (6) with ½ turn. The screw positioning bolt is for fixing the adjusted handle. Before actuating the handle, the screw positioning bolt must be unscrewed.
7. Insert o-ring gasket (4) in the groove in the handle (6).
8. Push handle (6) on screen socket (13) and lock with circlip (5).
9. Push indication disc (3) into gauge cover (2) and insert into handle (6).
10. The diaphragm (19) should easily screw onto the compressor. Upon meeting a resistance, turn the diaphragm back ¾ of a rotation and place the strap in the nearest recess.
11. Place assembled bonnet (1-19) on body (22) and secure with hex-screws (9), shims (10), hex-nuts (20) and mounting plate (23 only with PP material) the solid mounting plate (with DN 15/20 (OD 20/25) enables direct fixing of the hex-screws (9).
12. Place covering (8) on hex-screws (9) and hex-nuts(20)
13. Before installing the valve, a pressure test according to DIN 3230 must be performed.
14. **WELDED CONNECTION (A)**

Mount valve with butt, IR or socket welding tool into piping system

### **FLANGE CONNECTION (B)**

Insert valve with backing rings between pipe ends. Fix backing rings with screws. Be sure to align carefully and apply appropriate torque values during installation.

### **UNION CONNECTION**

Connect union adapter with the valve using the union nut

## Disassembling

1. Drain pipeline
2. Take coverings off.
3. Detach hex-nuts (20) and take off bonnet.
4. Turn diaphragm (19) off spindle (15)
5. Turn handle (6) clockwise to free compressor (17) and spindle (15).
6. Replace diaphragm (19) every time.
7. If necessary lubricate spindle (15) with SUNOCO Sunaplex 781.

## Installation

1. For pipe OD 20 and 25, the mounting hole inserts must be pushed through.
2. The valve should be mounted to a secure surface (i.e. wall, floor) to avoid excess stress on the piping.
3. When installing the valves, alignment with the pipe/fittings is crucial in order to get a secure, reliable joint. Installation should be performed by & experienced welder.
4. A pressure test should be conducted to confirm proper installation and the reliability of the joints.
5. Before the system is pressure tested, reference the torque values in Figure 3. The valve should not be under pressure during retightening.

MAX TORQUE (Nm)	
SIZE	HANDLE
DN 50	18
DN 32/40	15
DN 25	7
DN 15/20	6
SIZE	BACKING SCREW RING
DN 32-50	20
DN 15-25	15
SIZE	BONNET BOLTS
DN 50	20
DN 32/40	16
DN 25	10
DN 15/20	8

## Operation

**DO NOT OVER TIGHTEN THE HANDWHEEL** The hand wheel is intended to be tightened until "snug". Figure 4 shows the hand wheel with position indicator.

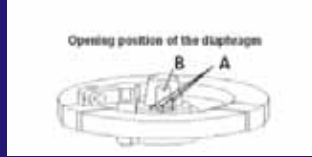

Figure 4: Hand wheel

To open the valve, turn the hand wheel **counter clockwise**. In order to close the valve, turn the hand wheel **clockwise**.

Figure 5 shows the relationship of operating pressure relative to the media temperature.

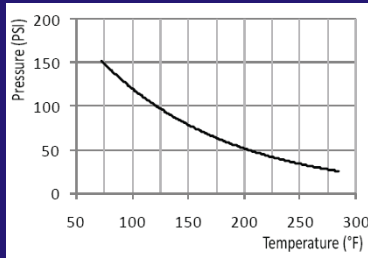

Figure 5: Maximum operating pressure as a function of temperature

Table 1 shows the Cv values for all valve sizes at different stages of opening

Table 1: Cv at open positions (GPM)

mm	inch	25%	50%	75%	100%
20	1/2	9.5	15.1	17.8	19.0
25	3/4	12.4	19.6	23.3	24.6
32	1	29.1	46.5	55.5	58.4
40	1-1/4	59.5	94.6	113.1	118.9
50	1-1/2	66.1	105.7	125.5	132.1
63	2	115.7	183.6	219.6	231.2
75	2-1/2	143.5	247.0	286.7	318.4
90	3	196.6	279.0	323.4	359.3
110	4	445.2	739.8	881.1	990.8

### ATTENTION:

**DO NOT DISASSEMBLE VALVE WHILE UNDER PRESSURE!  
ALWAYS DRAIN THE PIPE SYSTEM BEFORE DISASSEMBLING!**

35 Green Street, PO Box 653, Malden, MA 02148

Tel: (800) 343-3618, (781) 321-5409

Fax: (781) 321-4421

www.asahi-america.com - asahi@asahi-america.com

4-1-09