



Sight Glass Gauge Valves

Specifications

Sizes: 3/4" - 1"
Bodies: PVC and PP
Models: Flanged - ANSI
Diaphragms: EPDM, FKM and Others
Seals: EPDM, FKM and Others

Standard Features

- All-in-one sight glass isolation valve
- Eliminates the need for fittings and multiple valves
- No cementing required - sight glass connects and seals, using double O-rings in packing gland
- One valve closes connection to tank and opens connection to drain plug to permit fluid sampling
- Compact valve enables sight glass to be located close to tank
- Easy maintenance of sight glass

Sample Specification

All Sight Glass Gauge Valves shall be of thermoplastic construction (PVC or PP) and have no metal to media contact. PVC shall conform to ASTM D1784 Cell Classification 12454-A and PP shall conform to ASTM D4101 Cell Classification PPO210B67272. Valves shall be of compact design and shall eliminate the need for multiple valves and fittings. Valves shall incorporate a double O-ring union end design to allow easy maintenance of the glass, and a drain plug to permit sampling of fluid. All valves shall be rated to a maximum of 70 psi at 70 degrees F, as manufactured by Asahi/America, Inc.

Parts (Sizes 3/4" - 1")

PARTS			
NO.	DESCRIPTION	PCS.	MATERIAL
1	Body	1	PVC, PP
2	Bonnet	1	PVC, PP
3	Gland Nut	1	PVC, PP
4	Gland	1	PVC, PP
5	Hand Wheel	1	PP
6	Nut	1	Stainless Steel 304
7	Diaphragm	1	EPDM, FKM, Others
8	O-Ring (A)	1	EPDM, FKM, Others
9	Compressor	1	PVDF
10	Compressor Pin	1	Stainless Steel 304
11	Stem	1	Copper Alloy
12	Metal Insert In Bonnet	1	Copper Alloy
13	Indication of Material	1	Paper
14	Drain Plug	1	PVC
15	O-Ring (B)	1	EPDM, FKM

Weight (Pounds)

NOMINAL SIZE		FLANGED END	
INCHES	mm	PVC	PP
3/4	20	0.88	.66
1	25	1.32	1.10



Sight Glass Gauge Valves

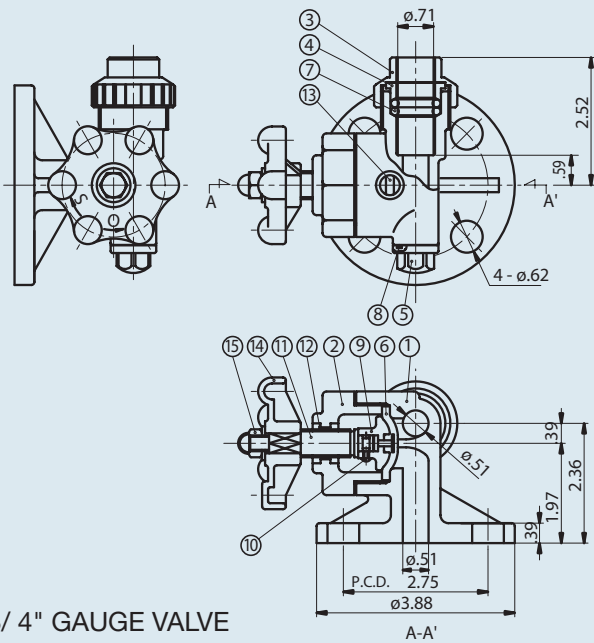

3/4" GAUGE VALVE

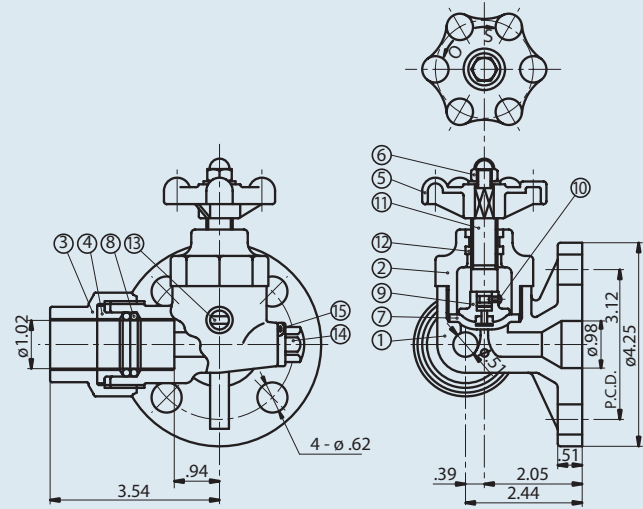

1" GAUGE VALVE

Tips On Gauge Valves

- To Install:
 1. Insert Asahi's low torque gasket between flanges.
 2. Insert bolts to mating flange and tighten by hand.
 3. Further tighten them with a torque wrench at a specified torque rating.
 4. Loosen union nut and insert sight glass.
 5. Tighten union nut by hand. Do not over-tighten it.
- To Operate:
 1. Use hand only.
 2. Just rotate handle gradually to close or open.
 3. Do not over-tighten.
- To Replace Parts:
 1. Drain fluid in the tank and valve completely.
 2. Loosen union nut and remove sight glass.
 3. Remove bolts and nuts.
 4. Loosen nut on top of the handle to remove handle.
 5. Loosen bonnet with a wrench and remove stem from bonnet.
 6. To remove compressor, loosen two pins that connect stem.

Troubleshooting

What if it leaks between bonnet and body?

1. Bonnet is not tightened properly. Retighten.
2. Media crystallized. Disassemble and clean.

What if diaphragm does not seal?

1. Foreign material caught between diaphragm and weir. Clean.
2. Diaphragm or weir is damaged. Replace diaphragm or replace body.

What if it leaks between Sight Glass and Union Nut?

1. Union nut is not tightened. Retighten.
2. Foreign material caught between glass and union nut. Clean it.
3. O-ring seal is damaged. Replace O-ring.
4. Sight glass is damaged. Change the sight glass.

What if it leaks from stem?

1. Diaphragm damaged or torn. Replace diaphragm.

Caution

- Never remove valve from tank before tank and valve are completely drained.
- Always wear protective gloves and goggles.
- Compressor and diaphragm cannot be disassembled.