

The Quarter master Protek Failsafe Electric Actuator features a rechargeable battery pack that is capable of 25 cycles under full load conditions, a built-in trickle charger; a low battery indicator; and an auxiliary limit switch that is calibrated with the fail position. The battery pack is installed inside of the actuator housing, so a separate enclosure to house the battery in not required.

When power is received from the primary power source, it is directed to the actuator motor and switches for normal cycling of the actuator. When the primary power source is interrupted, the battery pack is then connected to the motor and switches, and powers the actuator to the failsafe position. In this failsafe position, the auxiliary limit switch is tripped, and can be wired to an alarm. Once the primary power source is restored, the battery pack is disconnected and normal operation resumes.

Standard Features

- Compact design: Rechargeable battery pack is installed inside of actuator housing
- Battery indicator: "Low battery charge" indicator light is installed in one of the conduit entries for visual status of battery charge
- Trickle charger: Standard unit is equipped with built-in, automatic trickle charger to maintain full charge to battery pack
- Battery power: Unit is capable of 25 continuous cycles, under full load, using only battery pack
- Remote-local switch: Located inside of housing facilitates start-up and maintenance
- Fail position: Calibrated for fail open or fail close
- Extended duty cycle: 75% duty cycle motor
Gear train: Permanently lubricated
- Enclosure: Type 4X
- Corrosion resistant enclosure: Zytel FR50 engineered resin with SS trim
- ISO mounting configuration
- Conduit: 1/2" FNPT conduit entry
- Position indication: Highly visible position indicator for positive position of valve, even at a distance
- Dec clutchable manual override: Push down on handle and rotate in appropriate direction



Standard Features (continued)

- Limit switches: Unit is standard with two end of travel limit switches, and one auxiliary limit switch that is calibrated with the fail position
- Corrosion resistant mounting: Mounting is with PPG bracket, stainless steel coupling, and stainless steel fasteners

Output torque: Series 94 actuators have an output torque range from 150 in/lbs to 300 in/lbs

Options

- Voltages
- Heater and thermostat
- Additional limit switch
- Feedback potentiometer

Engineering Specifications

Size: A94, B94

Torque: 150 in/lbs - 300 in/lbs

Voltage: 120 VAC, 1-phase, 50/60Hz

Amp Draw: 0.2A - 4.0A

depending on supply voltage

Conduit Entry: one (1) 1/2" FNPT

Maximum Ambient Temperature: 150 F

Switches: three (3) SPDT, 15 amp rated. two (2) for end of travel, one (1) auxiliary calibrated with fail position.

Cycle Time per 90 : 5 seconds.

Maximum Battery Current Charge: 200mA

[13 Volts]

*Cycle times are approximate

Protek Battery Pack

Cycle Time and Wiring Diagram

Size	115 VAC		230 VAC		24 VAC		24 VDC		Cycle Time* 90 (SEC)
	Amp Draw	Duty Cycle	Amp Draw	Duty Cycle	Amp Draw	Duty Cycle	Amp Draw	Duty Cycle	
A94	0.4	75%	0.2	75%	4.0	75%	3.3	75%	5
B94	0.4	75%	0.2	75%	4.0	75%	3.3	75%	5
S92	0.4	75%	0.2	75%	4.0	75%	3.3	75%	15
A92	0.4	75%	0.2	75%	4.0	75%	3.3	75%	15
B92	0.4	75%	0.2	75%	4.0	75%	3.3	75%	32
C92	0.4	50%	0.2	50%	4.0	50%	3.3	50%	32

*Cycle times are approximate

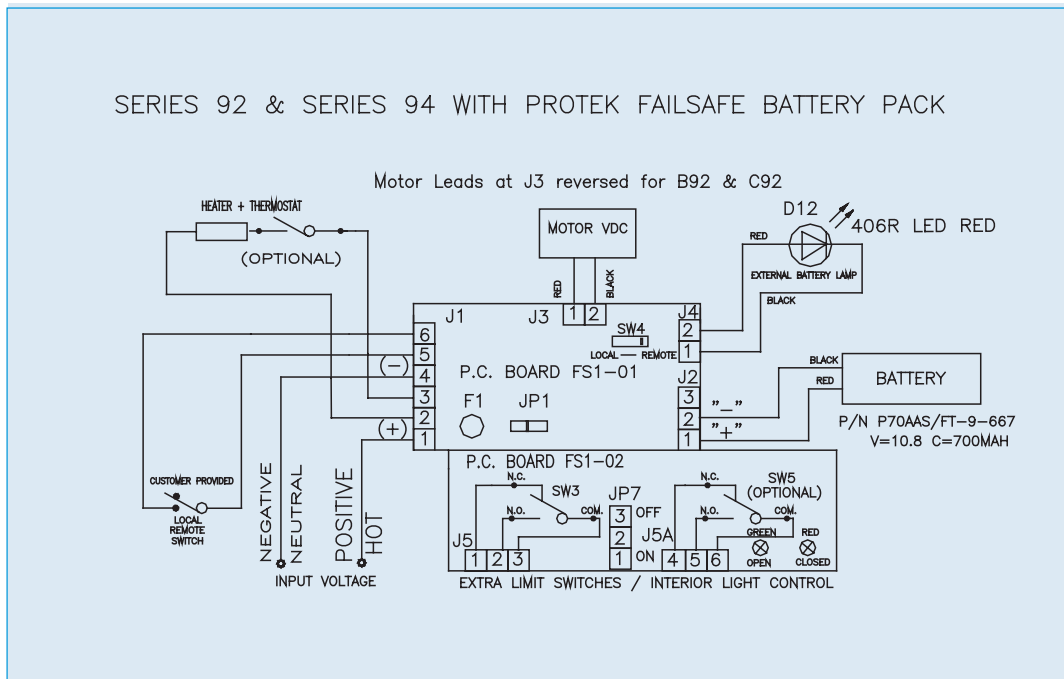

Failsafe electric actuators can be wired for operation in one of two ways.

1. Actuated valve in one position indefinitely, and fails to a predetermined position upon loss of power:

With jumper installed in Terminal #'s 5 & 6 (J1), provide constant power to Terminal #'s 1 & 4 (J1). This will hold the actuator in the open position as long as power is present. When the power is interrupted, the battery pack will close the actuator.

NOTE: This wiring configuration is ONLY for a valve that is not cycled.

2. Actuated valve cycles from open to close via supply power, and fails to a predetermined position upon loss of power:

With jumper removed from Terminal #'s 5 & 6 (J1), and a customer provided dry contact switch installed, provide constant power to Terminal #'s 1 & 4 (J1). When the dry contact switch is made, the valve will open. When the dry contact switch is not made, the valve will close. This task is completed via the supply power and does not affect the battery pack. When the supply power is interrupted, the valve will travel via battery pack power to a predetermined position