

Torque Air to Air (Inch-Pounds)

Model	Supply Pressure (psi)				
	40	60	80	100	120
A79PA	70	100	137	175	203
B79PA	103	142	201	261	300
B579PA	208	286	401	517	594
C79PA	291	404	575	741	853
C579PA	489	669	940	1212	1393
D79PA	688	947	1336	1724	1982
D579PA	1240	1682	2344	3008	3486
E79PA	2005	2720	3794	4868	5584
F79P	5155	6917	9558	12204	13965
G79P	8832	11983	16718	21452	24603
L79P	14496	19868	27922	35975	41347
M79P	21143	28966	40710	52454	60286

Cycle Time (Seconds)

Model	Air to Air		Air to Spring	
	Open Port A	Closed Port B	Open Port A	Closed Port B
A79PA	0.10	0.10	0.15	0.15
B79PA	0.15	0.15	0.20	0.20
B579PA	0.20	0.20	0.25	0.25
C79PA	0.25	0.25	0.30	0.30
C579PA	0.30	0.30	0.40	0.40
D79PA	0.40	0.40	0.50	0.50
D579PA	0.50	0.50	0.80	0.80
E79PA	0.60	0.60	1.20	1.20
F79P	1.20	1.20	2.00	2.00
G79P	2.00	2.00	6.00	6.00
L79P	4.00	4.00	11.00	8.00
M79P	6.00	6.00	15.00	10.00

Air Consumption (Cubic Inches)

Model	Air to Air		Air to Spring	
	Open Port A	Closed Port B	Open Port A	Closed Port B
A79PA	4.58	6.71	4.58	-
B79PA	9.15	10.98	9.15	-
B579PA	17.09	22.58	17.09	-
C79PA	21.36	27.46	21.36	-
C579PA	39.66	50.04	39.66	-
D79PA	48.82	70.17	48.82	-
D579PA	91.53	123.26	91.53	-
E79PA	125.09	115.94	125.09	-
F79P	323.41	323.41	323.41	-
G79P	640.71	427.14	640.71	-
L79P	1189.89	1263.11	1189.89	-
M79P	1891.62	1830.60	1891.62	-

Weight (Pounds)

Model	Air to Air	Air to Spring
A79PA	2.03	2.20
B79PA	3.09	3.58
B579PA	5.66	6.48
C79PA	6.79	7.67
C579PA	9.26	11.11
D79PA	12.36	14.61
D579PA	20.50	24.91
E79PA	20.06	35.04
F79P	38.79	80.23
G79P	67.66	128.71
L79P	106.45	142.82
M79P	171.69	260.51

Pneumatic Actuators

P/PA Series

Torque Air to Spring (Inch-Pounds)

MODEL	Spring Set	40 psi		60 psi		80 psi		100 psi		120 psi		Spring Torque	
		Start	End	Start	End	Start	End	Start	End	Start	End	Start	End
A79PAS	2	49	35	79	65	116	102	-	-	-	-	35	21
	3	38	21	68	51	105	89	143	127	-	-	49	32
	4	29	8	59	38	96	75	135	113	162	141	62	41
	5	-	-	49	25	86	62	124	100	151	127	75	51
	6*	-	-	-	-	78	49	116	87	143	114	89	59
B79PAS	2	71	51	111	91	169	150	-	-	-	-	51	32
	3	51	27	91	67	150	126	210	186	-	-	75	51
	4	-	-	75	44	134	103	194	163	233	202	98	67
	5	-	-	59	20	118	79	178	139	217	178	122	83
	6*	-	-	-	-	100	55	163	115	202	154	146	98
B579PAS	2	139	100	217	178	332	293	-	-	-	-	108	69
	3	108	46	186	124	301	239	417	355	-	-	162	100
	4	85	15	163	93	278	208	394	324	471	401	193	123
	5	-	-	132	47	247	162	363	278	440	355	239	154
	6*	-	-	-	-	216	123	332	239	409	316	278	185
C79PAS	2	200	157	312	269	484	441	-	-	-	-	135	91
	3	155	89	267	202	439	373	604	539	-	-	202	136
	4	110	22	222	135	394	306	559	472	672	584	269	181
	5	-	-	176	67	348	239	513	404	626	517	336	227
	6*	-	-	-	-	303	172	468	337	581	450	404	273
C579PAS	2	344	278	525	458	796	729	-	-	-	-	211	144
	3	272	173	452	353	723	624	995	896	-	-	316	217
	4	199	66	380	247	650	518	922	789	1104	971	422	289
	5	-	-	307	142	578	412	850	684	1031	866	527	362
	6*	-	-	-	-	506	307	778	579	959	760	633	434
D79PAS	2	494	379	753	638	1143	1027	-	-	-	-	309	194
	3	396	225	656	484	1045	873	1433	1261	-	-	463	291
	4	299	71	558	329	948	719	1335	1106	1594	1365	618	389
	5	-	-	462	175	851	565	1239	952	1497	1211	772	485
	6*	-	-	-	-	754	410	1142	797	1400	1056	927	582
D579PAS	2	888	704	1330	1146	1992	1808	-	-	-	-	536	352
	3	712	435	1154	878	1816	1540	2480	2204	-	-	804	528
	4	535	167	978	610	1640	1272	2304	1935	2782	2413	1073	704
	5	-	-	802	342	1464	1004	2128	1667	2605	2145	1341	881
	6*	-	-	-	-	1288	735	1951	1399	2429	1877	1609	1057
E79PS	1	1520	1174	2236	1890	3311	2965	-	-	-	-	830	484
	2	1174	689	1890	1405	2965	2478	4038	3553	-	-	1315	830
	3	759	205	1474	921	2549	1996	3622	3069	4338	3785	1799	1246
	4*	-	-	1128	298	2203	1373	3276	2446	3992	3162	2422	1592
F79PS	1	3589	2719	5351	4481	7995	7125	-	-	-	-	2436	1566
	2	2371	913	4133	2914	6776	5559	9420	8202	-	-	4003	2784
	3	-	-	3089	1348	5732	3992	8376	6636	10139	8398	5569	3829
	4*	-	-	-	-	4945	2774	7853	5417	9616	7180	6787	4351
G79PS	1	7003	5783	10157	8939	14886	13673	19621	18402	-	-	3050	1829
	2	5783	3649	8938	6803	13673	11532	18402	16267	21556	19421	5184	3050
	3	-	-	7413	4668	12142	9399	16877	14133	20031	17287	7319	4574
	4*	-	-	-	-	10319	6045	15047	10778	18202	13933	10673	6404
L79PS	2	10416	8368	15788	13744	23842	21798	-	-	-	-	6124	4089
	3	8372	5315	13744	10682	21798	18735	29851	26789	-	-	9177	6124
	4	6337	2255	11700	7624	19753	15682	27816	23736	33179	29099	12240	8160
	5	-	-	9664	4564	17718	12620	25771	20674	31143	26037	15303	10204
	6*	-	-	7624	1504	15682	9558	23736	17612	29099	22983	18364	12240
M79PS	2	15921	10700	23753	18532	35497	30276	-	-	-	-	10443	5222
	3	13310	5478	21143	13310	32887	25054	44631	36798	-	-	15656	7832
	4	-	-	18532	8089	30276	19833	42020	31577	49843	39409	20877	10443
	5	-	-	-	-	27665	14611	39409	26355	47241	34188	26099	13054
	6*	-	-	-	-	25054	9399	36798	21143	44631	28966	31320	15656

* Number of springs in standard unit

Pneumatic Actuators

P/PA Series

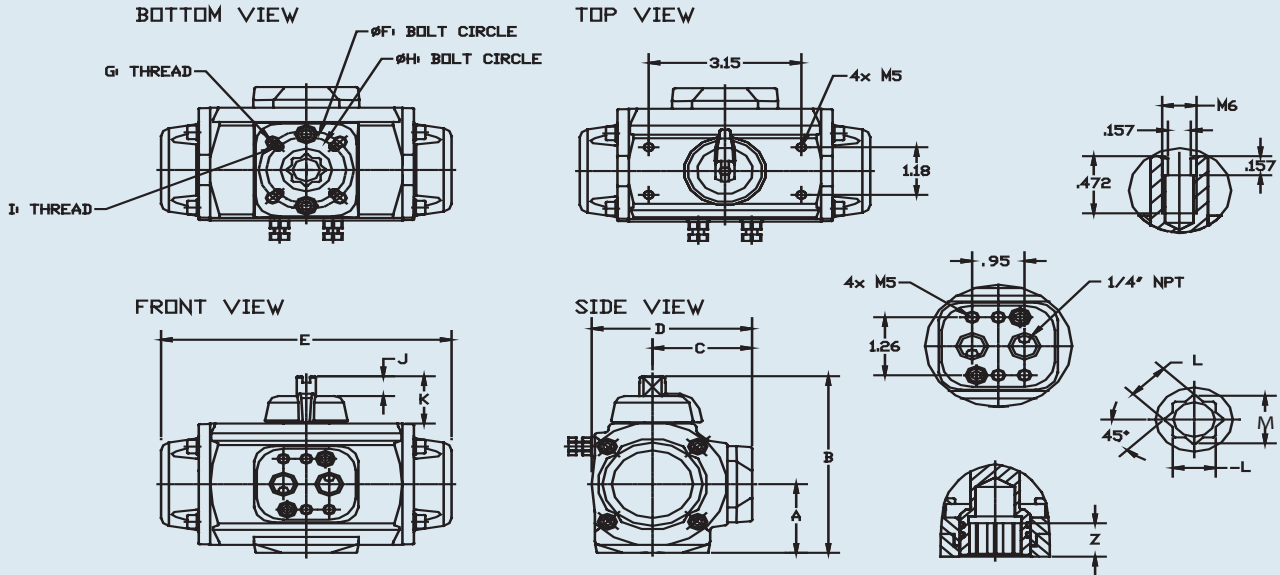

Model	A	B	C	D	E	F	G	H	I	J	K	L	M	Z
A79PA	1.47	3.52	1.90	3.00	5.52	1.65	M5 x 8 mm DEEP	1.42	M5 x 8mm DEEP	.32	.79	0.43	0.56	0.69
B79PA	1.70	4.38	2.06	3.31	6.00	1.97	M6 x 10 mm DEEP	1.65	M5 x 10mm DEEP	.49	1.18	0.55	0.75	0.70
B579PA	1.95	5.05	2.43	4.00	7.91	2.76	M8 x 14 mm DEEP	1.97	M6 x 9mm DEEP	.49	1.18	0.67	0.91	0.81
C79PA	2.06	5.21	2.47	4.08	8.84	2.76	M8 x 14 mm DEEP	1.97	M6 x 9mm DEEP	.49	1.18	0.67	0.91	0.82
C579PA	2.35	5.82	2.78	4.70	10.40	2.76	M8 x 14 mm DEEP	1.97	M6 x 9mm DEEP	.49	1.18	0.67	0.91	0.82
D79PA	2.51	6.15	2.96	5.02	12.19	2.76	M8 x 14 mm DEEP	1.97	M6 x 9mm DEEP	.49	1.18	0.67	0.91	0.82
D579PA	3.04	7.26	3.51	6.04	14.02	4.02	M10 x 15 mm DEEP	2.76	M8 x 14mm DEEP	.49	1.18	1.06	1.44	1.22

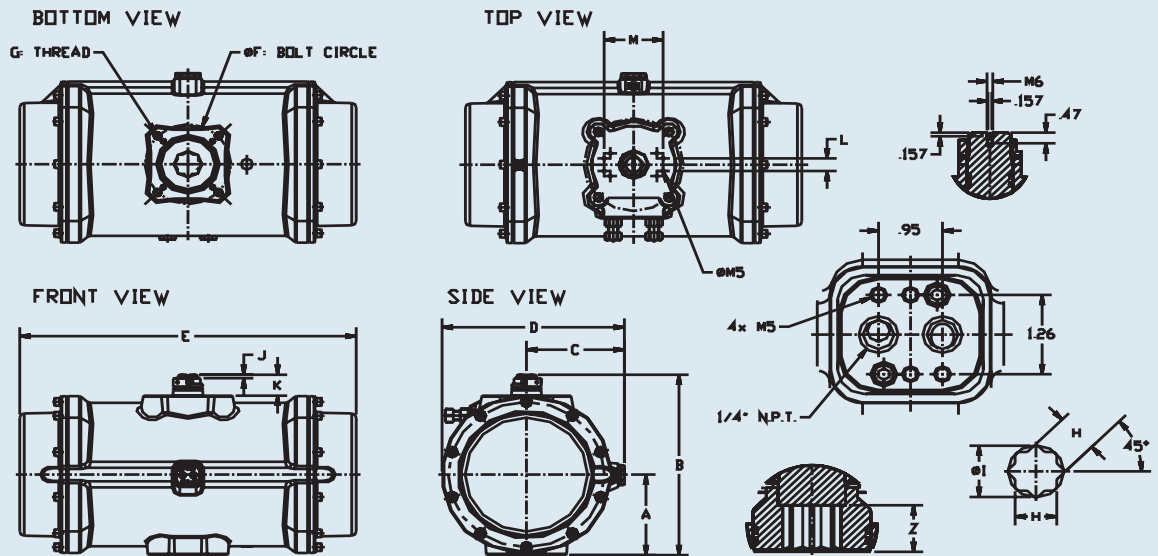

Model	A	B	C	D	E		F	G	H	I	J	K	L	M	Z
					A-A	A-S									
E79P	3.78	8.31	3.70	6.97	13.74	18.86	4.02	M10 x 15 mm DEEP	1.06	1.44	0.49	1.18	1.18	3.15	1.18
F79P	4.57	10.71	4.72	8.90	17.48	23.54	4.92	M12 x 18 mm DEEP	1.42	1.93	0.79	1.97	1.18	5.12	1.50
G79P	5.24	12.32	5.32	10.14	20.63	27.32	5.51	M16 x 25 mm DEEP	1.42	1.93	0.79	1.97	1.18	5.12	1.50
L79P	6.39	14.49	7.31	13.57	26.40	26.40	6.50	M20 x 25 mm DEEP	1.81	2.40	0.53	1.97	1.18	5.12	1.97
M79P	7.52	16.85	8.50	15.85	29.23	29.23	6.50	M20 x 25 mm DEEP	1.81	2.40	0.32	1.97	1.18	5.12	2.05