

# POLYVINYL CHLORIDE (PVC) AND CORZAN CHLORINATED POLYVINYL CHLORIDE (CPVC) PIPE

Industrial Technical Manual

## Major Advantages

### Easy Installation

PVC and CPVC pipe are light in weight (approximately one-half the weight of aluminum and one-sixth the weight of steel). They have smooth, seamless interior walls. No special tools are required for cutting. They can be installed using solvent cementing, threading, flanging and roll-grooved joining techniques.

### Chemical Resistance

PVC and CPVC pipe are inert to attack by strong acids, alkalis, salt solutions, alcohols, and many other chemicals. They are dependable in corrosive applications and impart no tastes or odors to materials carried in them. They do not react with materials carried, nor act as a catalyst. All possibility of contamination, or chemical process changes, and all danger of clouding, sludging, or discoloration are eliminated. (See chemical resistance charts.)

### Strength

PVC and CPVC pipe are highly resilient, tough and durable products that have high tensile and high impact strength. They will withstand surprisingly high pressure for long periods.

### Fire Resistance

PVC and CPVC pipe products are self extinguishing and will not support combustion. They have an ASTM E-84 flame spread rate of 25 or less.

### Internal Corrosion Resistance

PVC and CPVC pipe resist chemical attack by most acids, alkalis, salts, and organic media such as alcohols and aliphatic hydrocarbons, within certain limits of temperature and pressure. They provide the needed chemical resistance, while eliminating the disadvantages of special metals, lined piping, glass, wood, ceramics, or other special corrosion-resisting materials, which formerly had to be used.

### External Corrosion Resistance

Industrial fumes, humidity, salt water, weather, atmospheric, or underground conditions, regardless of type of soil or moisture encountered, cannot harm rigid PVC and CPVC plastic pipe. Scratches or surface abrasions do not provide points which corrosive elements can attack.

### Immunity to Galvanic or Electrolytic Attack

PVC and CPVC pipe are inherently immune to galvanic or electrolytic action. They can be used underground, underwater, in the presence of metals, and can also be connected to metals.

### Freedom from Toxicity, Odors, Tastes

PVC and CPVC piping are non-toxic, odorless, and tasteless. They have been listed by the National Sanitation Foundation for use with potable water.

### Corrosion Free

With many other pipe materials, slight corrosion may occur. The corroded particles can contaminate the piped fluid, complicating further processing, or causing bad taste, odors, or discoloration. This is particularly undesirable when the piped fluid is for domestic consumption. With PVC and CPVC, there are no corrosive by-products, therefore, no contamination of the piped fluid.

### Low Friction Loss

The smooth interior surfaces of PVC and CPVC pipe, compared to metal and other piping materials, assure low friction loss and high flow rates. Additionally, since PVC and CPVC pipe will not rust, pit, scale, or corrode, the high flow rates will be maintained for the life of the piping system.

### Low Thermal Conductivity

PVC and CPVC pipe have a much lower thermal conductivity factor than metal pipe. Therefore, fluids being piped maintain a more constant temperature. In most cases, pipe insulation is not required.

### Low Installation Cost

PVC and CPVC pipe are extremely light weight, convenient to handle, relatively flexible, and easy to install. These features lead to lower installed costs than conventional metal piping.

### Maintenance Free

Once a PVC or CPVC piping system is properly selected, designed, and installed, it is virtually maintenance free. It will not rust, scale, pit, corrode, or promote build-up on the interior. Therefore, years of trouble-free service can be expected when using Charlotte Pipe and Foundry PVC and CPVC pipe.

**Charlotte Pipe and Foundry PVC and Corzan CPVC pipe products meet or exceed all applicable NSF standards and are NSF listed for potable water. PVC AND CPVC PIPING PRODUCTS ARE NOT RECOMMENDED FOR SYSTEMS WHICH TRANSPORT OR STORE COMPRESSED AIR OR GASES. DO NOT TEST PVC OR CPVC PIPING SYSTEMS WITH COMPRESSED AIR OR GASES. ALWAYS BLEED ALL ENTRAPPED AIR FROM THE SYSTEM PRIOR TO TESTING.**

# PHYSICAL PROPERTIES OF PVC AND CORZAN CPVC MATERIALS

PROPERTY	PVC 1120	CPVC 4120	UNITS	ASTM No.
Specific Gravity	1.40	1.55	g/cc	D 792
Tensile Strength (73°F)	7,000	7,000	psi	D 638
Modulus of Elasticity in Tension (73°F)	400,000	360,000	psi	D 638
Flexural Strength (73°F)	14,000	15,100	psi	D 790
Izod Impact (notched at 73°F)	0.65	1.5	ft lb/ in.	D 256
Hardness (Durometer D)	80 ± 3	—		D 2240
Hardness (Rockwell R)	110 - 120	119		D 785
Compressive Strength (73°F)	9,600	10,100	psi	D 695
Hydrostatic Design Stress	2,000	2,000	psi	
Coefficient of Linear Expansion	3.0 x 10 <sup>-5</sup>	3.4 x 10 <sup>-5</sup>	in./ in./ °F	D 696
Heat Distortion Temperature at 264 psi	160	212	degrees F	D 648
Coefficient of Thermal Conductivity	1.2	.95	BTU/ hr/sq ft/ °F/ in.	C 177
Specific Heat	0.25	—	cal/ °C/ gm	D 2766
Water Absorption (24 hrs at 73°F)	.05	.03	% weight gain	D 570
Cell Classification	12454-B	23447		D 1784

Above data is based upon information provided by the raw material manufacturers. It should be used only as a recommendation and not as a guarantee of performance.

## PVC and CPVC Pipe Standards

TYPE PIPE	STANDARD SPECIFICATIONS	
	MATERIAL	DIMENSIONS
PVC SDR (Plain End)	ASTM D 1784	ASTM D 2241
PVC SDR (Belled-End)*	ASTM D 1784	ASTM D 2672
PVC Schedule 40	ASTM D 1784	ASTM D 1785
PVC Schedule 40 (DWV)	ASTM D 1784	ASTM D 2665
PVC Schedule 40 (Belled-End)*	ASTM D 1784	ASTM D 2672 or F 480
PVC Schedule 80*	ASTM D 1784	ASTM D 1785
CPVC Schedule 40 and 80	ASTM D 1784	ASTM F 441

\*See page 14 for socket dimensions of Belled-End pipe.

# HANDLING AND STORAGE OF PVC AND CPVC PIPE

## RECEIVING PIPE:

As pipe is received, it must always be thoroughly inspected, prior to unloading. The person receiving the pipe must look for any transportation damage caused by over-tightened tie-down straps, improper treatment, or a shift in the load.

Pipe received in a closed trailer must be inspected as the trailer is opened. Take extra time to ensure that the pipe has not been damaged by other materials having been stacked on top of it, load shift, or rough handling.

Visually examine the pipe ends for any cracks, splits, gouges, or other forms of damage. Additionally, the pipe should be inspected for severe deformation which could later cause joining problems. The entire inside diameter of larger diameter pipe (4" and above) must be checked for any internal splits or cracks which could have been caused by loading or transit. The use of a flashlight may be necessary to perform this inspection.

Any damages must be observed by all parties involved, including the driver, and should be clearly noted on the bill of lading and/or delivery ticket. A copy of this document should be retained by the receiver. In addition, the manufacturer and carrier should be notified, within 24 hours, of any damages, shortages, or mis-shipped products.

## HANDLING PIPE:

The pipe should be handled with reasonable care. Because thermoplastic pipe is much lighter in weight than metal pipe, there is sometimes a tendency to throw it around. This should be avoided.

The pipe should never be dragged or pushed from a truck bed. Removing and handling pallets of pipe should be done with a forklift. Loose pipe lengths require special handling to avoid damage.

Precautions to follow when unloading and handling loose pieces include not banging lengths together or dropping lengths, even from low heights, on hard or uneven surfaces.

In all cases, severe contact with any sharp objects (rocks, angle irons, forks on forklifts, etc.) should be avoided. Also, the pipe should never be lifted or moved by inserting the forks of a forklift into the pipe ends.

Handling PVC and particularly CPVC pipe diameters greater than 4-inch requires extra care as the added pipe weight can cause cracking from relatively minor impacts. Also, plastic pipe becomes more brittle as the temperature decreases. The impact strength and flexibility of PVC and especially CPVC pipe are reduced. Therefore, take extra care when handling skids or loose lengths when the temperature drops below 50° F.

## STORING PIPE:

If possible, pipe should be stored inside. When this is not possible, the pipe should be stored on level ground which is dry and free from sharp objects. If different schedules of pipe are stacked together, the pipe with the thickest walls should be on the bottom.

If the pipe is in pallets, the pallets should be stacked with the pallet boards touching, rather than pallet boards being placed on the pipe. This will prevent damage to or bowing of the pipe.

If the pipe is stored in racks, it should be continuously supported along its length. If this is not possible, the spacing of the supports should not exceed three feet (3').

The pipe should be protected from the sun and be in an area with proper ventilation. This will lessen the effects of ultraviolet rays and help prevent heat build-up.



# DIMENSIONS AND WEIGHTS

## PVC and CPVC Schedule 40 Pipe

Nominal Pipe Size (in.)	Outside Diameter	Min. Wall	Approximate Wt. (lbs/100 ft)	
			PVC	CPVC
1/2	.840	.109	16.2	17.3
3/4	1.050	.113	21.4	23.0
1	1.315	.133	31.5	34.2
1 1/4	1.660	.140	42.6	46.3
1 1/2	1.900	.145	50.8	55.3
2	2.375	.154	68.2	74.3
2 1/2	2.875	.203	107.0	117.9
3	3.500	.216	140.8	154.2
4	4.500	.237	200.5	219.6
5	5.563	.258	272.5	—
6	6.625	.280	353.3	386.1
8	8.625	.322	538.6	581.1
10	10.750	.365	755.0	823.8
12	12.750	.406	1001.0	1089.2
14	14.000	.438	1180.1	—
16	16.000	.500	1543.1	—

## PVC and CPVC Schedule 80 Pipe

Nominal Pipe Size (in.)	Outside Diameter	Min. Wall	Approximate Wt. (lbs/100 ft)	
			PVC	CPVC
1/4	.540	.119	10.0	10.9
3/8	.675	.126	13.8	15.0
1/2	.840	.147	20.4	22.1
3/4	1.050	.154	27.0	30.0
1	1.315	.179	41.0	44.2
1 1/4	1.660	.191	52.2	61.0
1 1/2	1.900	.200	66.8	73.9
2	2.375	.218	94.5	102.2
2 1/2	2.875	.276	144.5	155.9
3	3.500	.300	194.2	208.6
4	4.500	.337	275.2	304.9
5	5.563	.375	387.3	—
6	6.625	.432	541.5	581.5
8	8.625	.500	805.2	882.9
10	10.750	.593	1200.0	1309.1
12	12.750	.687	1650.0	1801.2
14	14.000	.750	1930.0	—
16	16.000	.843	2544.1	—

Note: All dimensions are in inches.

# PRESSURE RATINGS

## MAXIMUM OPERATING PRESSURE (PSI) AT 73°F

Nominal Pipe Size	Schedule 80 PVC and CPVC		Schedule 40 PVC and CPVC (2)	SDR 26 PVC (2)	SDR 21 PVC (2)	SDR 13.5 PVC (2)
	Plain End	Threaded				
1/4	1130	570	780	—	—	—
3/8	920	460	620	—	—	—
1/2	850	420	600	—	—	315
3/4	690	340	480	—	200	—
1	630	320	450	—	200	—
1 1/4	520	260	370	160	200	—
1 1/2	470	240	330	160	200	—
2	400	200	280	160	200	—
2 1/2	420	210	300	160	200	—
3	370	190	260	160	200	—
4	320	160	220	160	200	—
5	290	Threading	190	160	200	—
6	280	pipe above	180	160	200	—
8	250	4" is not	160	160	200	—
10	230	recommended	140	160	200	—
12	230		130	160	200	—
14	220 (1)		130 (1)	160	—	—
16	220 (1)		130 (1)	160	—	—

The operating pressures listed above are based on the hydrostatic design of the pipe using water at 73° F as the test medium. See page 17 for correction factors for temperatures above 73° F.

The PVC pipe shown is for PVC 1120 with a cell class of 12454-B. The CPVC pipe shown is for CPVC 4120 with a cell class of 23447.

The pressure ratings for the pipe shown were derived by using the following equation:

$$P = \frac{2ST}{D-T}$$

- Where: **P** = pressure (psi)  
**D** = average outside diameter  
**T** = minimum wall thickness  
**S** = hydrostatic design stress (HDS)\*

\*The HDS for Charlotte Pipe and Foundry's PVC and CPVC compounds is 2,000 psi.

(1) PVC only.

(2) Threading is not recommended. Also, PVC and CPVC Schedule 80 pipe operating above 130° F should not be threaded.

**PVC AND CPVC PIPING PRODUCTS ARE NOT RECOMMENDED FOR SYSTEMS WHICH TRANSPORT OR STORE COMPRESSED AIR OR GASES. DO NOT TEST PVC OR CPVC PIPING SYSTEMS WITH COMPRESSED AIR OR GASES. ALWAYS BLEED ALL ENTRAPPED AIR FROM THE SYSTEM PRIOR TO TESTING.**

# PRESSURE/TEMPERATURE RELATIONSHIP

---

The operating pressure of PVC and CPVC pipe will be reduced as the operating temperature increases above 73°F. To calculate this reduction, multiply the operating pressures shown on the previous page by the correction factors shown below:

<b>Operating Temperature (°F)</b>	<b>Correction Factors</b>	
	<b>PVC</b>	<b>CPVC</b>
73	1.00	1.00
80	.88	1.00
90	.75	.91
100	.62	.82
110	.50	.77
120	.40	.65
130	.30	.62
140	.22	.50
150	NR	.47
160	NR	.40
170	NR	.32
180	NR	.25
200	NR	.20

For example, the operating pressure for 6" Schedule 80 CPVC pipe is 280 psi. If the operating temperature is 140° F, the maximum operating pressure is now 140 psi (280 x .50).

Note: Operating temperatures above 140° F for PVC and 200° F for CPVC piping products are not recommended.

# FLUID FLOW PROPERTIES

---

## Entrapped Air

### Source

There are many potential sources for air in pipelines. Air may be introduced at the point where fluid enters the system or during initial filling of the system.

### Problem

Air in a piping system tends to accumulate at high points in the system. As the flowrate increases, the entrapped air is forced along the pipeline by the moving water. These pockets of air cause flow restrictions reducing the efficiency and performance of the system. Water is about 5 times more dense than air at 100 psi, so when a pocket of air reaches an outlet, it escapes rapidly and water rushes to

replace the void. Such pressure surges can easily exceed the strength of a piping system and its components.

### Solution

Designers should be concerned about entrapped air, but the issue of entrapped air is very complex. The behavior of air in a piping system is not easy to analyze, but the effects can be devastating. Obviously, the best way to reduce problems would be to prevent air from entering the system. Systems should be filled slowly and air vented from the high points before the system is pressurized. Additionally, air relief valves should be installed at high points in the system to vent air that accumulates during service.

# WEATHERING

---

## UV Exposure

PVC pipe can suffer surface discoloration when exposed to ultraviolet (UV) radiation from sunlight. UV radiation affects PVC when energy from the sun causes excitation of the molecular bonds in the plastic. The resulting reaction occurs only on the exposed surface of the pipe and to the extremely shallow depths of .001 to .003 inches. The effect does not continue when exposure to sunlight is terminated.

A two-year study was undertaken to quantify the effects of UV radiation on the properties of PVC pipe (See Uni-Bell's UNI-TR-5). The study found that exposure to UV radiation results in a change in the pipe's surface color and a reduction in impact strength. Other properties such as tensile strength (pressure rating) and modulus of elasticity (pipe stiffness) are not adversely affected.

The presence of an opaque shield between the sun and the pipe prevents UV degradation. UV radiation will not penetrate thin shields such as paint coatings or wrappings. Burial of PVC pipe provides complete protection against UV attack.

The most common method used to protect above ground PVC pipe from the sun is painting with a latex (water base) paint. Preparation of the surface to be painted is very important. The pipe should be cleaned to remove moisture, dirt, and oil and wiped with a clean, dry cloth. Petroleum-based paints should not be used, since the presence of petroleum will prevent proper bonding of paint to pipe.

Reference Uni-Bell PV Pipe Association 2001

# SUPPORT SPACING FOR PVC AND CORZAN CPVC PIPE

Adequate support for any piping system is a matter of great importance. In practice, support spacings are a function of pipe size, operating temperatures, the location of heavy valves or fittings, and the mechanical properties of the pipe material.

To ensure the satisfactory operation of a PVC or CPVC piping system, the location and type of hangers should be carefully considered. The principles of design for steel piping systems are generally also applicable to PVC and CPVC piping systems, but with some notable areas where special consideration should be exercised.

- (1) Concentrated loads (valves, flanges, etc.) should be supported directly so as to eliminate high stress concentrations. Should this be impractical, then the pipe must be supported immediately adjacent to the load.
- (2) In systems where large fluctuations in temperature occur, allowance must be made for expansion and contraction of the piping system. Since changes in direction in the system are usually sufficient to allow expansion and contraction, hangers must be placed so as not to restrict this movement.
- (3) Changes in direction should be supported as close as practical to the fitting to avoid introducing excessive torsional stresses into the system.

- (4) Since PVC and CPVC pipe expand or contract approximately five times as much as steel, hangers should not restrict this movement. When using a clamp type hanger, the hanger should not force the pipe and fittings into position.
- (5) Hangers should provide as much bearing surface as possible. To prevent damage to the pipe, file smooth any sharp edges or burrs on the hangers or supports.
- (6) Valves should be braced against operating torque.
- (7) PVC and CPVC lines must not be placed alongside steam or other high temperature pipe lines or other high temperature objects.
- (8) Support spacing for horizontal piping systems is determined by the maximum operating temperatures the systems will encounter. The piping should be supported on uniform centers with supports that do not restrict the axial movement of the pipe. The chart below shows the recommended support spacing according to size, schedule, and operating temperatures. These spacings apply to continuous spans of uninsulated lines, with no concentrated loads, conveying liquids with specific gravities of up to 1.00.

## SUPPORT SPACING (IN FEET)

Nom. Pipe Size (in.)	PVC PIPE															CPVC PIPE											
	PR 160 & 200					Schedule 40					Schedule 80					Schedule 40						Schedule 80					
	Temp. °F					Temp. °F					Temp. °F					Temp. °F						Temp. °F					
	60	80	100	120	140	60	80	100	120	140	60	80	100	120	140	60	80	100	120	140	180	60	80	100	120	140	180
1/2	3 1/2	3 1/2	3	2		4 1/2	4 1/2	4	2 1/2	2 1/2	5	4 1/2	4 1/2	3	2 1/2	5	5	4 1/2	4 1/2	4	2 1/2	5 1/2	5 1/2	5	4 1/2	4 1/2	2 1/2
3/4	4	3 1/2	3	2		5	4 1/2	4	2 1/2	2 1/2	5 1/2	5	4 1/2	3	2 1/2	5 1/2	5	5	4 1/2	4	2 1/2	5 1/2	5 1/2	5 1/2	5	4 1/2	2 1/2
1	4	4	3 1/2	2		5 1/2	5	4 1/2	3	2 1/2	6	5 1/2	5	3 1/2	3	6	5 1/2	5 1/2	5	4 1/2	2 1/2	6	6	6	5 1/2	5	3
1 1/4	4	4	3 1/2	2 1/2		5 1/2	5 1/2	5	3	3	6	6	5 1/2	3 1/2	3	6	5 1/2	5 1/2	5 1/2	5	3	6 1/2	6 1/2	6	6	5 1/2	3
1 1/2	4 1/2	4	4	2 1/2		6	5 1/2	5	3 1/2	3	6 1/2	6	5 1/2	3 1/2	3 1/2	6 1/2	6 1/2	6 1/2	5 1/2	5	3	7	7	6 1/2	6	5 1/2	3 1/2
2	4 1/2	4	4	3		6	5 1/2	5	3 1/2	3	7	6 1/2	6	4	3 1/2	6 1/2	6	6	5 1/2	5	3	7	7	7	6 1/2	6	3 1/2
2 1/2	5	5	4 1/2	3		7	6 1/2	6	4	3 1/2	7 1/2	7 1/2	6 1/2	4 1/2	4	7 1/2	7	7	6 1/2	6	3 1/2	8	7 1/2	7 1/2	7 1/2	6 1/2	4
3	5 1/2	5 1/2	4 1/2	3		7	7	6	4	3 1/2	8	7 1/2	7	4 1/2	4	8	7	7	7	6	3 1/2	8	8	8	7 1/2	7	4
4	6	5 1/2	5	3 1/2		7 1/2	7	6 1/2	4 1/2	4	9	8 1/2	7 1/2	5	4 1/2	8 1/2	7 1/2	7 1/2	7	6 1/2	4	9	9	9	8 1/2	7 1/2	4 1/2
6	6 1/2	6 1/2	5 1/2	4		8 1/2	8	7 1/2	5	4 1/2	10	9 1/2	9	6	5	9 1/2	8 1/2	8	7 1/2	7	4 1/2	10	10 1/2	9 1/2	9	8	5
8	7	6 1/2	6	5		9	8 1/2	8	5	4 1/2	11	10 1/2	9 1/2	6 1/2	5 1/2	9 1/2	8 1/2	8	7 1/2	7	5	11	11	10 1/2	10	9	5 1/2
10						10	9	8 1/2	5 1/2	5	12	11	10	7	6	10	9 1/2	9	8	7 1/2	5 1/2	11 1/2	11 1/2	11	10 1/2	9 1/2	6
12						11 1/2	10 1/2	9 1/2	6 1/2	5 1/2	13	12	10 1/2	7 1/2	6 1/2	10 1/2	10 1/2	10	9	8	6	12 1/2	12 1/2	12 1/2	11	10 1/2	6 1/2
14						12	11	10	7	6	13 1/2	13	11	8	7												
16						12 1/2	11 1/2	10 1/2	7 1/2	6 1/2	14	13 1/2	11 1/2	8 1/2	7 1/2												

This data is based upon information provided by the raw material manufacturers. It should be used only as a reference and not as a guarantee of performance. Installations must comply with all local plumbing codes and regulations.

# RECOMMENDED PIPE HANGERS, CLAMPS, AND SUPPORTS

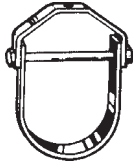

Clevis Hanger  
1/2 to 30 in. pipe



Band Hanger  
1/2 to 8 in. pipe



Split Ring Hanger  
3/8 to 8 in. pipe



Split Ring Hanger  
Adj. Swivel Ring  
3/4 to 8 in. pipe

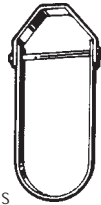

Adj. Clevis  
For Insulated Lines  
3/4 to 12 in. pipe



Adj. Swivel Ring  
1/2 to 8 in. pipe

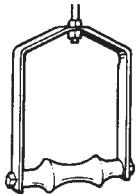

Roller Hanger  
2 1/2 to 20 in. pipe

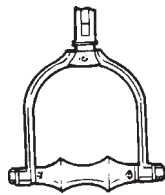

Adj. Swivel Roller Hanger  
2 1/2 to 12 in. pipe

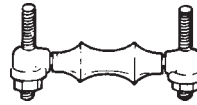

Single Pipe Roll  
1 to 30 in. pipe

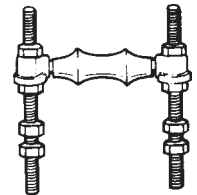

Adj. Pipe Roll Support  
1 to 30 in. pipe

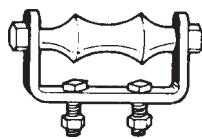

Roller Chair  
2 to 12 in. pipe

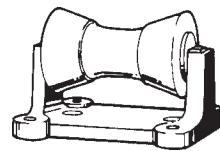

Pipe Roll Stand  
2 to 42 in. pipe



Pipe Clamp  
1/2 to 24 in. pipe

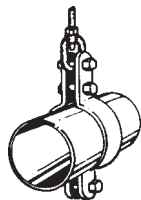

Double Bolt Pipe Clamp  
3/4 to 36 in. pipe

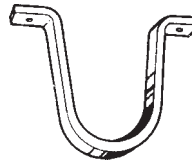

Anchor Strap  
1/2 to 4 in. pipe

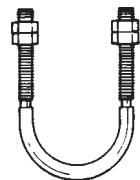

U Bolt  
1/2 to 30 in. pipe

# EXPANSION AND CONTRACTION OF ABS, PVC, AND CPVC

ABS and PVC pipe, like other piping materials, undergo length changes as a result of temperature variations above and below the installation temperature. They expand and contract 4.5 to 5 times more than steel or iron pipe. The extent of the expansion or contraction is dependent upon the piping material's coefficient of linear expansion, the length of pipe between directional changes, and the temperature differential.

The coefficients of linear expansion (Y) for ABS, PVC, and CPVC (expressed in inches of expansion per 10°F temperature change per 100 feet of pipe) are as follows:

Material	Y (in./10°F/100 ft)
ABS	0.66
PVC	0.36
CPVC	0.408

The amount of expansion or contraction can be calculated using the following formula:

$$\Delta L = \frac{Y (T_1 - T_2)}{10} \times \frac{L}{100}$$

$\Delta L$  = Dimensional change due to thermal expansion or contraction (in.)

Y = Expansion coefficient (See table above.) (in./10°F/100 ft)

(T<sub>1</sub>-T<sub>2</sub>) = Temperature differential between the installation temperature and the maximum or minimum system temperature, whichever provides the greatest differential (°F).

L = Length of pipe run between changes in direction (ft)

Example:

How much expansion can be expected in a 300 foot straight run of 2" diameter PVC pipe installed at 70°F and operating at 120°F?

Solution:

$$\Delta L = .360 \frac{(120 - 70)}{10} \times \frac{300}{100} = .360 \times 5 \times 3 = 5.4 \text{ inches}$$

There are several ways to compensate for expansion and contraction. The most common methods are:

1. Expansion loops which consist of pipe and 90° elbows (See Figure 1)
2. Piston type expansion joints\* (See Figure 2)
3. Flexible bends\*
4. Bellows and rubber expansion joints\*

\*The manufacturers of these devices should be contacted to determine the suitability of their products for the specific application.

Expansion loops are a simple and convenient way to compensate for expansion and contraction when there is sufficient space for the loop in the piping system. A typical expansion loop design is shown below.

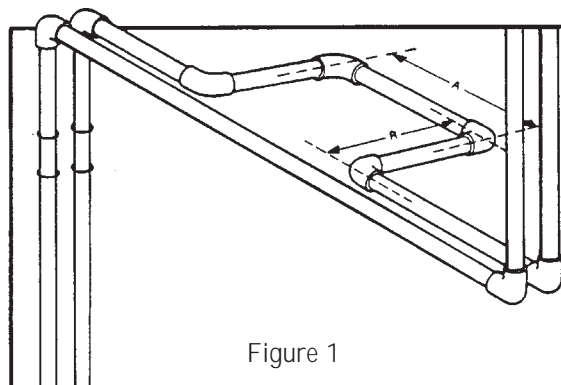

Figure 1

The length of leg "R" can be determined by using the following formula to ensure that it is long enough to absorb the expansion and contraction movement without damage. The length of leg "A" should be 1/2 the length of leg "R".

$$R = 1.44 \sqrt{D \Delta L}$$

R = Expansion loop leg length (ft)

D = Nominal outside diameter of pipe (in.) (See table below.)

$\Delta L$  = Dimensional change due to thermal expansion or contraction (in.)

Example: How long should the expansion loop legs be to compensate for the expansion in a system that has 215 feet of 3" diameter PVC pipe installed at 75°F and operating at 135°F?

$$\text{Solution: } R = 1.44 \sqrt{3.500 \times 4.644} = 1.44 \sqrt{16.254} = 5.80'$$

$$A = \frac{5.80'}{2} = 2.90'$$

When installing the expansion loop, no rigid or restraining supports should be placed within the leg lengths of the loop. The loop should be installed as closely as possible to the mid-point between anchors. Piping support guides should restrict lateral movement and direct axial movement into the loop. Lastly, the pipe and fittings should be solvent cemented together, rather than using threaded connections.

Compensation for expansion and contraction in underground applications is normally achieved by snaking the pipe in the trench. Solvent cemented joints must be used.

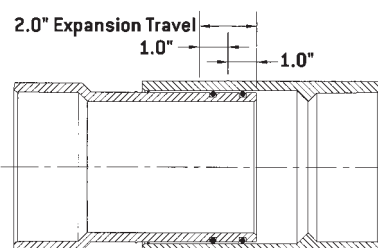

Figure 2

Expansion Joint - Charlotte Part No. 133

# UNDERGROUND INSTALLATION

ABS, PVC, and CPVC pipe and fittings can be installed underground. Since these piping systems are flexible systems, proper attention should be given to burial conditions. The stiffness of the piping system is affected by sidewall support, soil compaction, and the condition of the trench. Trench bottoms should be smooth and regular in either undisturbed soil or a layer of compacted backfill. Pipe must lie evenly on this surface throughout the entire length of its barrel. Excavation, bedding and backfill should be in accordance with the provisions of the local Plumbing Code having jurisdiction.

## Trenching

The following trenching and burial procedures should be used to protect the piping system.

1. The trench should be excavated to ensure the sides will be stable under all working conditions.
2. The trench should be wide enough to provide adequate room for the following.
  - A. Joining the pipe in the trench.
  - B. Snaking the pipe from side to side to compensate for expansion and contraction.
  - C. Filling and compacting the side fills.

The space between the pipe and trench wall must be wider than the compaction equipment used in the compaction of the backfill. Minimum width shall be not less than the greater of either the pipe outside diameter plus 16 inches or the pipe outside diameter times 1.25 plus 12 inches. Trench width may be different if approved by the design engineer.

3. The trench bottom should be smooth, free of rocks and debris, continuous, and provide uniform support. If ledge rock, hardpan or large boulders are encountered, the trench bottom should be padded with bedding of compacted granular material to a thickness of at least 4 inches. Foundation bedding should be installed as required by the engineer.
4. Trench depth is determined by the pipe's service requirements. Plastic pipe should always be installed at least below the frost level. The minimum cover for lines subject to heavy overhead traffic is 24 inches.
5. A smooth, trench bottom is necessary to support the pipe over its entire length on firm stable material. Blocking should not be used to change pipe grade or to intermittently support pipe over low sections in the trench.

Compensation for expansion and contraction in underground applications is normally achieved by snaking the pipe in the trench. Solvent cemented joints must be used.

The following table shows recommended offsets and loop lengths for piping up to 2 1/2" nominal size.

Loop Length In Feet	Max. Temp. Variation °F, Between Installation and Final Operation									
	10°	20°	30°	40°	50°	60°	70°	80°	90°	100°
20	3.0	3.5	4.5	5.0	6.0	6.5	7.0	7.0	8.0	8.0
50	7.0	9.0	11.0	13.0	14.0	15.5	17.0	18.0	19.0	20.0
100	13.0	18.0	22.0	26.0	29.0	31.5	35.0	37.0	40.0	42.0

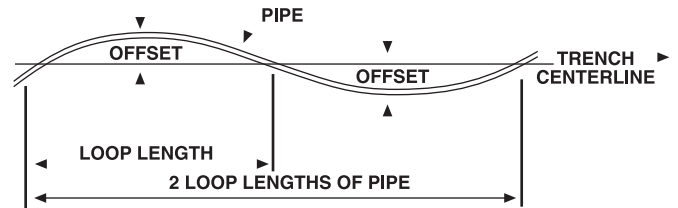

## Bedding and Backfilling

1. Even though sub-soil conditions vary widely from place to place, the pipe backfill should be stable and provide protection for the pipe.
2. The pipe should be surrounded with a granular material which is easily worked around the sides of the pipe. Backfilling should be performed in layers of 6 inch with each layer being sufficiently compacted to 85% to 95% compaction.
3. A mechanical tamper is recommended for compacting sand and gravel backfill which contain a significant proportion of fine grained material, such as silt and clay. If a tamper is not available, compacting should be done by hand.

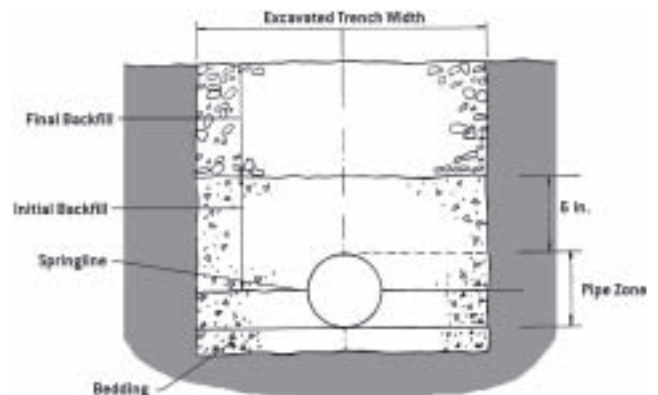

4. The trench should be completely filled. The backfill should be placed and spread in fairly uniform layers to prevent any unfilled spaces or voids. Large rocks, stones, frozen clods, or other large debris should be removed. Heavy tampers or rolling equipment should only be used to consolidate only the final backfill.

Additional information is contained in ASTM D 2321 "Underground Installation of Thermoplastic pipe for sewers and other gravity-flow applications."

## Solvent Cementing PVC and CPVC Pipe and Fittings

### BASIC PRINCIPLES OF SOLVENT CEMENTING

To make consistently good joints the following should be clearly understood:

1. The joining surfaces must be softened and made semi-fluid.
2. Sufficient cement must be applied to fill the gap between pipe and fitting.
3. Assembly of pipe and fittings must be made while the surfaces are still wet and fluid.
4. Joint strength develops as the cement dries. In the tight part of the joint the surfaces will tend to fuse together, in the loose part the cement will bond to both surfaces.

Penetrating and softening can be achieved by the use of both primer and cement. A suitable primer will usually penetrate and soften the surfaces more quickly than the cement alone. Additionally, the use of a primer can provide a safety factor for the installer, for he can know, under various temperature conditions, when he has achieved sufficient softening. For example, in cold weather more time and additional applications are required.

### PRIMERS AND CEMENTS

#### Primer

It is recommended that a high quality primer be used to prepare the surfaces of pipe and fittings for solvent welding. Do not use water, rags, gasoline, or any other substitutes for cleaning PVC or CPVC surfaces. A chemical cleaner such as MEK may be used.

#### Cement

Make sure the solvent cement used is suitable for the type and size of the pipes being installed. PVC cement must be used with PVC pipe and fittings. CPVC cement must be used with CPVC pipe and fittings. Also, cement with the proper viscosity for the type and size of pipe, must be used. Contact the supplier of the cement if there are any questions on the suitability of the cement for the intended application.

Solvent cements are formulated to be used "as received" in original containers. Adding of thinners to change viscosity is

not recommended. If the cement is found to be jelly-like and is not free-flowing, it should not be used. Containers should be kept covered when not in actual use.

Solvent cements should be stored at temperatures between 40° F and 110° F and away from heat or open flame. The cements should be used within one year of the date stamped on the container. Stocks should be constantly rotated to prevent build-up of old cement inventories. If new cement is subjected to freezing it may become extremely thick or gelled. This cement can be placed in a warm area where, after a period of time, it will return to its original, useable condition. But such is not the case when gellation has taken place because of actual solvent loss; for example, when container was left open too long during use or not sealed properly after use. Cement in this condition has lost its formulation and should be discarded.

Solvent cements and primers are extremely flammable and should not be used or stored near heat or open flame. They should be used only with adequate ventilation. In confined or partially enclosed areas, a ventilating device should be used to remove vapors and minimize their inhalation. Containers should be kept tightly closed when not in use and covered as much as possible when in use. Avoid frequent contact with the skin. In case of eye contact, flush repeatedly with water. Keep out of reach of children.

### Applicators

To properly apply the primer and cement, the correct size and type of applicator must be used. There are three basic types of applicators:

**Daubers** — should only be used on pipe sizes 2" and below, and should have a width equal to 1/2 the diameter of the pipe.

**Brushes** — can be used on any diameter pipe, should always have natural bristles, and should have a width equal to at least 1/2 the diameter of the pipe.

**Rollers** — can be used on 4" and larger diameter pipe and should have a length equal to at least 1/2 the diameter of the pipe.



## 5. Dry Fitting

Check dry fit of pipe and fitting by inserting pipe into fitting. With light pressure, pipe should easily go at least 1/3 of the way in. If it bottoms, it should be snug.



## 6. Priming

Using the correct applicator (as shown in chart), apply primer freely to fitting socket, keeping the surface and applicator wet until the surface has been softened. This will usually require 5-15 seconds. More time is needed for hard surfaces and in cold weather conditions. Redip the applicator in primer as required. When the surface is primed, remove any puddles of primer from the socket.

A second application in the socket is recommended if it has unusually hard surfaces. These hard surfaces are often found in belled-ends and in fittings made from pipe stock.

Apply the primer to the end of the pipe equal to the depth of the fitting socket. Application should be made in the same manner as was done on the fitting socket.



## 7. Cementing

While the surfaces of the pipe and fitting are still wet with primer, immediately apply a full even layer of cement to the pipe using the proper size applicator shown in chart) equal to the depth of the socket.



Apply a medium layer of cement to the fitting socket. Do not let the cement puddle. Also, when joining belled-end pipe, do not coat beyond the bell depth or allow the cement to run down the inside of the pipe.



Apply a second full even layer of cement to the pipe. Assemble parts QUICKLY! Parts must be assembled while cement is still fluid. If assembly is interrupted, recoat parts and assemble. Push pipe FULLY into fitting, using a turning motion, if possible, of 1/8 to 1/4 turn, until it bottoms. Hold them together for 15 - 30 seconds to offset tendency of pipe to move out of fittings. With a rag, wipe off excess bead of cement from juncture of pipe and fitting.



**Note:** For pipe sizes 6" and larger, two people will be required, a mechanical forcing device should be used, and the joint should be held together for up to 3 minutes.



# FLANGING PVC AND CPVC PIPE

For systems where dismantling is required, flanging is a convenient joining method. It is also an easy way to join plastic and metallic systems.

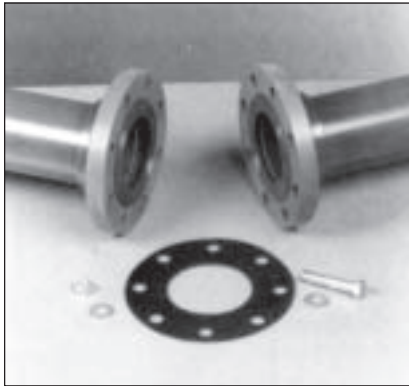

5. Use a torque wrench to tighten the bolts to the torque values shown below.



## INSTALLATION

1. Join the flange to the pipe using the procedures shown in the solvent cementing or threading sections (pages 30-35).
2. Use a full faced elastomeric gasket which is resistant to the chemicals being conveyed in the piping system. A gasket 1/8" thick with a Durometer, scale "A", hardness of 55 - 80 is normally satisfactory.
3. Align the flanges and gasket by inserting all of the bolts through the mating flange bolt holes. Be sure to use properly sized flat washers under all bolt heads and nuts.
4. Sequentially tighten the bolts corresponding to the patterns shown below.

## RECOMMENDED TORQUE

Pipe Size In Inches	No. Bolt Holes	Bolt Diameter	Recommended Torque ft/lbs
1/2	4	1/2	10 - 15
3/4	4	1/2	10 - 15
1	4	1/2	10 - 15
1 1/4	4	1/2	10 - 15
1 1/2	4	1/2	10 - 15
2	4	5/8	20 - 30
2 1/2	4	5/8	20 - 30
3	4	5/8	20 - 30
4	8	5/8	20 - 30
6	8	3/4	33 - 50
8	8	3/4	33 - 50
10	12	7/8	53 - 75
12	12	7/8	53 - 75

Note: Flanges meet the bolt-pattern requirements of ANSI / ASME B 16.5

## FLANGE BOLT TIGHTENING SEQUENCE

