

# Butterfly Valve Type 57

## Parts Identification

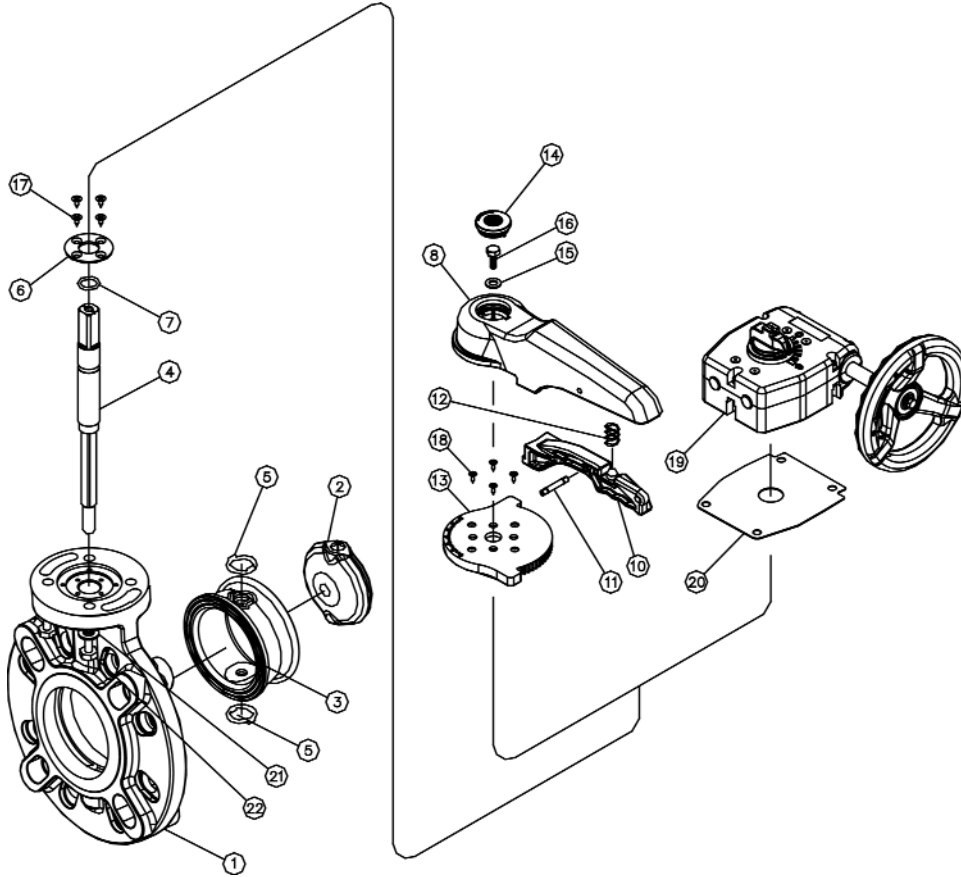

ITEM	QTY	DESCRIPTION
1	1	BODY
2	1	DISC
3	1	SEAT
4	1	STEM
5	2	LINER STABILIZATION RING
6	1	STEM HOLDER
7	1	O-RING (C)
7a	1	KEY
8	1	HANDLE
10	1	HANDLE LEVER
11	1	PIN
12	1	SPRING
13	1	LOCKING PLATE
14	1	CAP
15	1	WASHER (A)
16	1	BOLT (A)
17	4	SCREW (A)
18	4	SCREW (B)
19	1	GEAR OPERATOR
20	1	GASKET
21	4	WASHER
22	4	BOLT

## Installation Procedure

### Caution

- 1) The valve disc is set in the position indicated by the solid lines in Fig. 5-1 prior to shipment from the factory. If the valve is opened or closed after unpacking, it must be reset in this position before installation. Failure to do so will result in damage to the surface of the valve seat during handling and installation.
- 2) The valve must not be dropped or come in contact with other objects, as the sealing surface of the disc and the sealing surface of the valve seat may be damaged.
- 3) Care must be used during piping installation to ensure that the pipes or flanges are properly aligned so that the valve disc does not come in contact with them. Misalignment as shown in Fig. 5-2 will result in damage to the valve.
- 4) The installed valve must never be opened or closed when foreign matter such as sand is present in the pipeline.

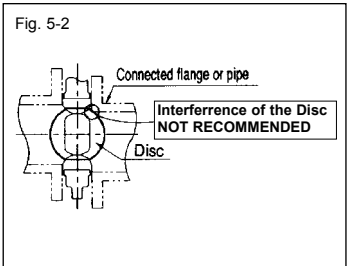
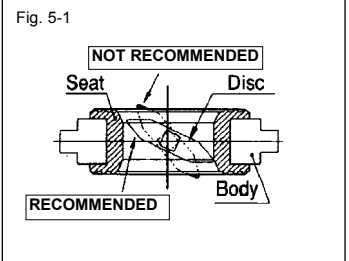

To avoid interference the piping ID must be equal to or larger than the D dimension shown in the following chart. If pipe interference is evident spacers or chamfering of the pipe or fitting is required.

Nominal Size	Diameter D (inch)	Nominal Size	Diameter D (inch)	Nominal Size	Diameter D (inch)
1-1/2"	1.34	4"	3.66	10"	9.33
2"	1.77	5"	4.65	12"	11.38
2-1/2"	2.36	6"	5.47	14"	13.39

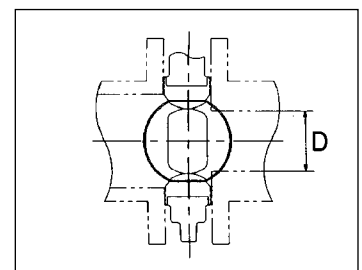

**Procedure**

- 1) Install the valve between flanges with the valve slightly open. (Refer to Fig. 5-3)
- 2) Insert bolts, nuts and washers and tighten the bolts and nuts temporarily by hand.
- 3) Open the valve fully to check for pipe interference before fully tightening the bolts.

The parallelism and axial misalignment of the flange surface should be under the values shown in the following table to prevent damage to the valve.

Unit: inch

Nominal Size	Axial misalignment	Parallelism (a – b)
1 1/2" – 3"	0.04	0.03
4" – 6"	0.04	0.04
8" – 14"	0.06	0.04

(Refer to Fig. 5-4)

- 4) Tighten the bolts and nuts gradually with a torque wrench to the specified torque level in a diagonal manner. (Refer to Table 5-1 and Figure 5-5)

Table 5-1 Recommended torque value Unit: foot-lbs

Nominal Size	Torque value	Nominal Size	Torque value
1 1/2"	14	8" - 10"	40
2" - 2 1/2"	16	12" - 14"	43
3" - 4"	22		
5" - 6"	32		

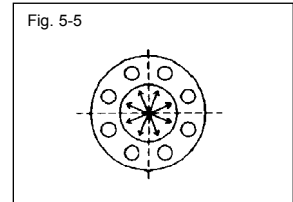
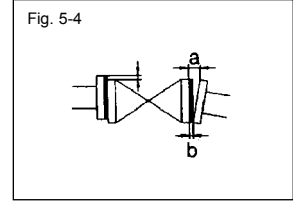
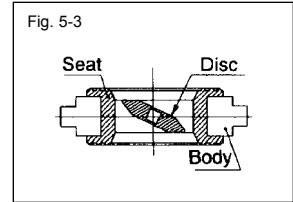

**Installation Procedure for Handle**

Install the handle on the stem. Set the direction of handle to correspond with the indication line at the top of stem.

- 1) Secure the handle at the top of stem with the enclosed bolt and washer by using a socket wrench.
- 2) Set the cap on top of the handle and gently strike it with a rubber or plastic hammer, until it is seated.

Nominal Size	1 1/2" – 4"	5" – 8"
Bolt Size	M6 x 15L	M8 x 15L
Socket Size	10 MM	13 MM

**Removal Procedure**

- 1) To remove the cap, insert a screwdriver into the indentation, then push down and pry out.
- 2) Remove the bolt and washer by using a socket wrench, then remove the handle.

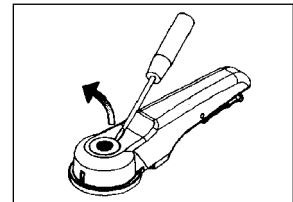
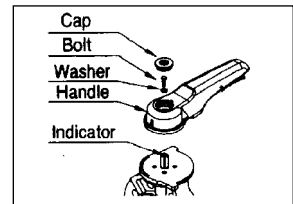

## Adjustment Procedure for Travel Stop Gear Type

The adjustments for full-opened and full-closed position are preset at the factory. If adjustment is required refer to the following procedure:

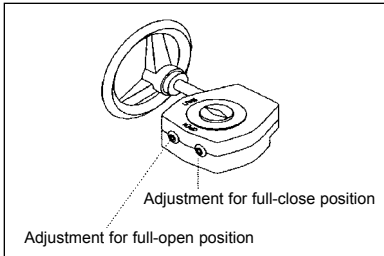

### Adjustment for Full Closed (Full Opened) Position

- 1) Remove the protective rubber caps
- 2) Loosen the stop hex-bolt with an allen wrench.
- 3) Adjust the disc of valve to the required position.
- 4) Tighten the stop hex-bolts.
- 5) Replace the protective rubber caps.

## Disassembly and Assembly Procedure for Parts Replacement

### Caution

- 1) Wear protective gloves and goggles in case some dangerous fluid remains in the valve body.  
(You could be injured by working without them.)
- 2) The handle part [16] can be removed with line pressure present. The locking plate [22] can not be removed with line pressure present. If locking plate [22] needs to be removed, there can not be line pressure present.
- 3) The gear operator [25] can not be removed with line pressure present. If the gear box parts [25] need to be removed, there can not be line pressure present.

### << Disassembly >>

- 1) Drain the fluid completely from the pipeline.
  - 2) Leave the valve slightly opened.
  - 3) Loosen the flange bolts and nuts.
  - 4) Remove the valve from the pipeline.
  - 5) Lever type:  
To remove the handle [16], first remove the cap [24] by using a flat head screw driver and bolt [21] by using a socket wrench, then pull up the lever [17] and remove the handle [16].  
To take off the locking plate [22], remove the four self tapping screws [23] by using a philips screw driver and remove the stem holder [8].
  - Gear type:  
Remove bolts [28] from gear box and pull upward to remove gear box [25].
  - 6) Secure the flat surface of Stem [7] with a vise and pull or press away valve body [1].
  - 7) For up to 12" sizes, set the valve body [1] on supports at edges of the valve body. Press out the disc and seat as one piece using a press or non metallic object to prevent damage.
- For further details consult O&M User's manual.

### << Assembly >>

- 1) Before starting the assembly, silicone grease (equivalent to Troy Silicone HVG) should be spread on the disc O-rings [4][5] and stem O-ring [6].
  - 2) The procedure of the assembly is the almost reverse of its disassembly. However, to insert the seat [3] with the disc [2] into the body [1], set the disc [2] in the half – opened position. Press outer rim of seat [3] into inside of the body [1], keeping stem holes aligned.  
(Make sure that stem holes of the seat [3] are in alignment with the stem holes of the body [1].)
  - 3) After assembly, make sure that the valve can be fully opened and closed smoothly.
- For further details consult O&M User's manual.

### Working Pressure Vs. Temperature

(PSI, WATER, NON-SHOCK)

Body	PVC			PP		PVDF			
Disc	PP			PP		PVDF			
Nominal Size (inches)	30° F	121° F	141° F	-5° F	141° F	-5° F	141° F	176° F	211° F
	120° F	140° F	175° F	140° F	175° F	140° F	175° F	210° F	250° F
1 1/2" - 3"	150	70	30	150	100	150	100	85	75
4" - 6"	150	45	30	150	100	150	100	85	75
8" - 10"	150	40	20	150	85	150	85	75	60
12"	100	30	15	100	60	100	60	45	30
14"	100	30	7	100	45	100	45	30	15

Note: Consult factory for pressure ratings for lug style.

## Operating procedure

- Open and close the valve by turning handle slowly. Turn clockwise to close and counterclockwise to open.
- Lever type, the direction of handle is same as the disc.  
For the full-closed position, the handle is perpendicular to the piping system.  
For the full-opened position, the handle is parallel to the piping system.
- Gear type, the indicator shows the position of the disc on the top of gear box.  
For the full-closed position, the indication shows Shut.  
For the full-opened position, the indication shows Open.

## General Operating Instructions

- Operate the valve within the Pressure Vs Temperature range.  
(The valve can be damaged by operating beyond the allowable range.)
- Select a valve material that is compatible with the media, refer to "CHEMICAL RESISTANCE ON ASAHI AV VALVE".  
(Some chemicals may damage incompatible valve materials.)
- Do not step on the valve or apply excessive weight on the valve. (It can be damaged.)
- Allow sufficient space for maintenance and inspection.
- Keep the valve away from excessive heat or fire. (It can be deformed or destroyed.)
- Make sure to consult a waste treatment dealer to dispose of the valves.  
(Poisonous gas is generated when the valve is burned improperly.)

**Caution: Do not change or replace valve parts under line pressure.**  
**Refer to O&M User's manual for further details.**

## General Instructions for Transportation, Unpacking and Storage

- Keep the valve packed in the carton or box as delivered until installation.
- Keep the valve away from any coal tar, creosote (antiseptic for wood), termite insecticide, vermicides, and paint.  
(This could cause swelling and damage the valve.)
- Do not impact or drop the valve. (It can be damaged.)

## Visual Maintenance Inspection

- (1) Check for flaws, cracks, or deformation on the valve.
- (2) Check for leaks to the outside.
- (3) Check for the deformation of seat or disc due to improper installation of valve.
- (4) Check for the smoothness of handle operation.

## Troubleshooting

Problem	Cause	Treatment
Fluid leaks in the full closed position.	<ol style="list-style-type: none"> <li>1) The travel stop is not set correctly.</li> <li>2) The seat is damaged or worn.</li> <li>3) Foreign materials are trapped.</li> <li>4) The disc is damaged or worn.</li> <li>5) The flange bolts are over tightened or tightened unevenly.</li> </ol>	Adjust the stop. Replace the seat. Remove the material. Replace the disc. Adjust and retighten.
Fluid leaks to the outside.	<ol style="list-style-type: none"> <li>1) The seat is damaged or worn.</li> <li>2) The connecting bolts are not tightened properly or torqued unevenly.</li> </ol>	Replace the seat. Adjust and retighten the bolts.
The handle does not operate smoothly.	<ol style="list-style-type: none"> <li>1) Foreign materials have collected on the disc or seat.</li> <li>2) The gearbox is damaged.</li> <li>3) The flange bolts are over tightened.</li> </ol>	Remove the material. Repair or replace. Adjust and retighten the flange bolts.
Valve does not operate.	<ol style="list-style-type: none"> <li>1) The gear box is damaged.</li> <li>2) The stem is damaged.</li> </ol>	Repair or replace. Replace the stem.

**If you would like more details about this valve, please request the O & M User's Manual.**



ASAHI/AMERICA® 35 Green Street, P.O. Box 653, Malden, MA 02148 • Tel: (781) 321-5409 • Fax: (781) 321-4421