

AS-i Bus System

AS-i Bus System

Pneumatic Specifications

Mounting:	ISO/NAMUR
Connection:	M12 SS
AS-i Current Draw:	.16 AMP
Electrical Design:	2-input/2-output
Voltage Range:	26.5-31.6 VDC
Sensor/relay supply:	AS-i
Air Connection:	1/4" FNPT
Solenoid coil:	Epoxy encapsulated
Solenoid protection:	Type 4x Reverse polarity protected



Series 79 Pneumatic Actuator

A group of European Automation Companies had a vision for a simple, cost effective networking system. These companies worked together for a common goal, and in 1993 the AS-i (Actuator Sensor Interface) Network was formed.

AS-i (Actuator-Sensor Interface) offers many of the benefits of more complex and costly bus systems, but does it at a substantially lower cost and with greater simplicity. The Actuator-Sensor Interface is ideally suited for controlling valves, actuators and many other field devices in your processing application.

This interface can be used for stand-alone process control, or it can be used together with a higher-level bus control system. AS-interface does not compete with higher-level bus systems; it should be seen as a complimentary system that offers low cost, reliable device control for binary and analog devices.

Reliability, simplicity and interoperability make AS-interface a cost effective connection/control solution, particularly where low installation costs is imperative.

A single pair of wires, which handles power and communications, is used to control the network by means of "chaining" the actuators with the PLC. Each actuator (or device) will then have its own unique address within the system and only that device with the proper address will respond to system commands.

AS-i is best known for its yellow flat cable, which is pierced by insulation displacement connectors so that the expense of tees and complex connectors is avoided. Devices are simply clamped onto the cable.

Digital signals are encoded on this cable in a sinusoidal signal, which has a very narrow frequency bandwidth. Filtering, which is distributed through the network, rejects all extraneous frequencies, and in this way AS-i can be operated in electrically noisy environments without experiencing transmission errors.

The yellow flat cable carries low current (30 VDC) for input devices such as solenoids, relays, etc. as well as the AS-i signal. If power for outputs (such as electric actuators) is required, an additional BLACK flat cable is available.

AS-i Bus System



**Series 79 Pneumatic Actuator
and Ball Valve**



**Series 79 Pneumatic Actuator
and Butterfly Valve**

Standard Features

- Low profile, compact package for ease in mounting where space limitations are an issue.
- Actuators and accessories meet ISO and NAMUR standards, therefore, no special training is required for field installation/conversion.
- M12 SS connection utilized for network interfacing - Type 4X rated.
- No moving parts with proximity sensor triggered by a target puck.
- Sealed proximity switch so open cavity condensation is not an issue.
- Each actuator has visual indication and proximity feedback to the PLC.
- Each component meets Type 4X.
- Low power consumption allows power and data communications via the same two-wire cable.
- A system of 31 valves requires less than 5 amps of AS-i power.
- Expandability with gateway and/or insulation displacement connector.
- 5 ms reaction time from PLC to cycling of unit.
- Conformance to AS-i Certificate ZU15101.

Sample Specification

All pneumatically actuated AS-interface systems shall have a 2-input/2-output proximity sensor and a solenoid directly mounted to a Series 79 actuator. The sensor shall be constructed of Pocan® Thermoplastic Polyester; Type 4X protection, operation and function LED's, voltage range of 20-30 VDC, and a stainless steel M12 socket connection to the network. The solenoid shall have an anodized aluminum body with a 1/4" NPT air inlet, manual over-ride, and NEMA 4X protection. Spool/piston shall be synthetic resin with NBR and FKM O-rings, and fitted with an epoxy-encapsulated coil directly coupled to the proximity sensor, as supplied by Asahi/America, Inc.

AS-i Bus System

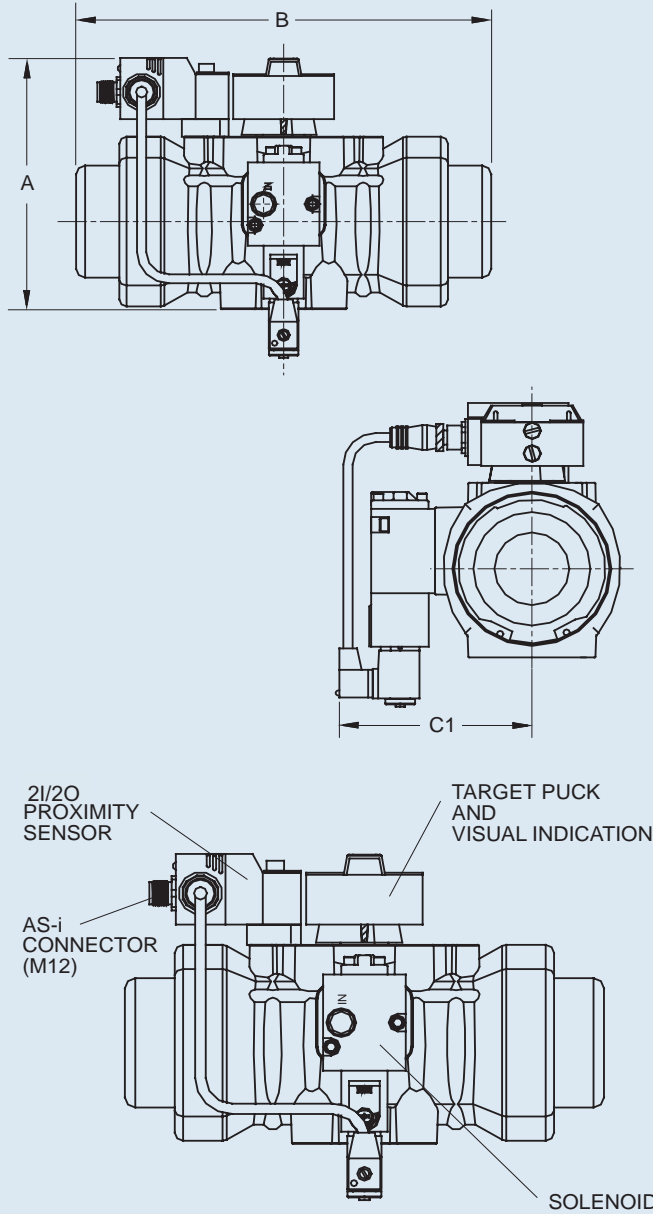

Dimensions (IN.)

Series	A	B	C1
AP79PN	4.36	4.22	3.52
AP79PSN	4.36	5.55	3.52
BP79PN	5.38	4.92	3.78
BP79PSN	5.38	6.22	3.78
CP79PN	5.62	7.01	4.22
CP79PSN	5.62	9.06	4.22
DP79PN	6.96	9.21	4.69
DP79PSN	6.96	12.13	4.69
E79PAN	8.89	12.13	5.59
E79PASN	8.89	18.50	5.59
F79PN	11.47	15.98	6.18
F79PSN	11.47	25.43	6.18
G79PN	12.67	20.63	7.25
G79PSN	12.67	27.32	7.25